

Premier Series High Pressure Performance Piston Pumps

For Open Circuits (SAE, ISO, DIN)

Catalog: HY28-2702-01/PRE/US



ENGINEERING YOUR SUCCESS.

Hydraulic Pump and Power Systems Division and Denison Hydraulics

The Hydraulic Pump and Power Systems Division of Parker Hannifin was formed in 2004 when our significant piston pump business was expanded through the acquisition of **Denison Hydraulics**. The addition of **Denison** allowed us to marry the wealth of knowledge that both companies have in the design, manufacture, and application of piston products in both open circuit and closed circuit system applications. Since before WWII, **Denison** products have been chosen for Military test stand applications and for shipboard hydraulic applications being recognized as technology leaders.

The division is a leading worldwide manufacturer of hydraulic components and systems for earthmoving and construction vehicles; for mining equipment; for pulp and paper, chemical and other processing equipment; for ships and ordnance equipment; and for such in-plant machines as machine tools, plastic molding, die casters, and stamping presses.



DENISON Hydraulics

The product information, specifications, and descriptions contained in this publication have been compiled for the use and convenience of our customers from information furnished by the manufacturer; and we can not, and do not, accept any responsibility for the accuracy or correctness of any description, calculation, specification, or information contained herein. No such description, calculation, specification, or information regarding the products being sold has been made part of the basis of the bargain, nor has same created or amounted to an express warranty that the products would conform thereto. We are selling the goods and merchandise illustrated and described on this publication on an "as is" basis, and disclaim any implied warranty, including any warranty of merchantability or warranty of fitness for any particular purpose whatsoever, with respect to the goods and merchandise sold. All manufacturer warranties shall be passed on to our customers, but we shall not be responsible for special, indirect, incidental, or consequential damages resulting from the use of any of the products or information contained or described on this publication. Further, we reserve the right to revise or otherwise make product improvements at any time without notification.



WARNING - USER RESPONSIBILITY

FAILURE OR IMPROPER SELECTION OR IMPROPER USE OF THE PRODUCTS DESCRIBED HEREIN OR RELATED ITEMS CAN CAUSE DEATH, PERSONAL INJURY AND PROPERTY DAMAGE.

This document and other information from Parker-Hannifin Corporation, its subsidiaries and authorized distributors provide product or system options for further investigation by users having technical expertise.

The user, through its own analysis and testing, is solely responsible for making the final selection of the system and components and assuring that all performance, endurance, maintenance, safety and warning requirements of the application are met. The user must analyze all aspects of the application, follow applicable industry standards, and follow the information concerning the product in the current product catalog and in any other materials provided from Parker or its subsidiaries or authorized distributors.

To the extent that Parker or its subsidiaries or authorized distributors provide component or system options based upon data or specifications provided by the user, the user is responsible for determining that such data and specifications are suitable and sufficient for all applications and reasonably foreseeable uses of the components or systems.

OFFER OF SALE

The items described in this document are hereby offered for sale by Parker-Hannifin Corporation, its subsidiaries or its authorized distributor. This offer and its acceptance are governed by the provisions stated in the detailed "Offer of Sale" elsewhere in this document.

Contents

Contents

Technical Data2
Features4
Description5
Dimensions6
Performance Curves
 P05/P08010
 P07/P11012
 P09/P14014
 P12/P20016
 P16/P26018
Rear Adapters22
Maximum Bending Moment on Premier Series Flange.....30
Pump Primary Displacement Control Options.....32
Secondary Control Options.....38
Identification Ports and Adjustments40
Ordering Code41
Offer of Sale.....43



Series	Terms	P05/080	P07/110	P09/140	P12/200	P16/260	
Displacement	Max. displacement	in³/rev.	4.9	6.7	8.6	12.2	16.0
		cm ³ /rev.	80,3	109,8	140,9	200,0	262,2
Pressure	Continuous	psi	6000	6000	6000	6000	6000
		bar	414	414	414	414	414
	1) Intermittent	psi	7250	7250	7250	7250	7250
		bar	500	500	500	500	500
Speed	@ atmospheric inlet	rpm	2550	2450	2300	2100	1850
	max. with boost	rpm	3200	3000	2800	2700	2100*
Mounting	Flange-4 bolt	SAE	152-4 (D)	152-4 (D)	152-4 (D)	165-4 (E)	165-4 (E)
		ISO3019/2B4HW	180	180	180	224	250
	Shaft - <i>keyed</i>	SAE	44-1 (D)	44-1 (D)	44-1 (D)	44-1 (E)	44-1 (E)
		ISO 3019/2	40mm	40mm	50mm	50mm	50mm
		DIN 6885	40mm	40mm	50mm	50&60mm	60mm
	Shaft - <i>splined</i>	SAE	44-4 (D)	44-4 (D)	44-4 (D)	44-4 (E)	44-4 (E)
		ISO 4156	40mm	40mm	50mm	50mm	50mm
		DIN 5480	40mm	40mm	50mm	50&60mm	60mm
Shaft - <i>splined</i> (Hi-Torque P16 only)	SAE	N/A	N/A	N/A	N/A	50-4 (F)	
Weight	lbs	156	177	220	300	325	
Mass	kg.	71	80	100	136	147	
Rotating inertia	lbs/in²	65	92	152	245	see below	
	kg.m ²	0,019	0,027	0,044	0,072	see below	
Rotating inertia	(P16/260H) lbs/in²	-	-	-	-	349	
	kg.m ²	-	-	-	-	0,102	
Rotating inertia	(P16/260Q) lbs/in²	-	-	-	-	360	
	kg.m ²	-	-	-	-	0,105	
Case pressure: maximum allowable	continuous	psi	25	25	25	25	25
		bar	1,7	1,7	1,7	1,7	1,7
	intermittent	psi	50	50	50	50	50
		bar	3,4	3,4	3,4	3,4	3,4

Controls

Compensator response (per SAE J497 @ 5000 psi , 345 bar)							
	off-stroke	sec.	0.06	0.07	0.06	0.09	0.10
	on-stroke	sec.	0.11	0.13	0.11	0.15	0.15
Compensator adjustment	psi/turn	2000	2000	2000	2000	2000	
	bar/turn	138	138	138	138	138	
Minimum compensating pressure (compensator, torque limiter, or load sensing)	psi	250	250	250	250	250	
	bar	17,2	17,2	17,2	17,2	17,2	
Minimum servo pressure	psi	800	800	700	700	700	
	bar	55	55	48	48	48	
Maximum servo pressure	psi	1500	1500	1500	1500	1500	
	bar	103	103	103	103	103	
Min. comp. override pressure at above listed min. servo. (servo, electric & hydraulic stroker)	psi	1500	1500	1050	1050	1050	
	bar	103	103	72,4	72,4	72,4	
Handwheel turns, full to zero stroke	turns	9.0	9.3	8.1	9.5	10.2	
Torque to turn handwheel at 1000 psi , 70 bar	in.-lbs	75	100	125	140	150	
	Nm	9	11	15	16	17	
Torque to turn handwheel at 7250 psi , 500 bar	in.-lbs	175	225	275	315	350	
	Nm	20	25	32	36	40	
Servo shaft rotation, 0 to full stroke	degrees	47-52°	47-52°	52-57°	60-65°	65-70°	
Torque to turn rotary servo shaft	in.-lbs	20	20	20	20	20	
	Nm	2,3	2,3	2,3	2,3	2,3	

*P16H, P260H only

1) 10% of operation time, not exceeding 6 consecutive seconds.



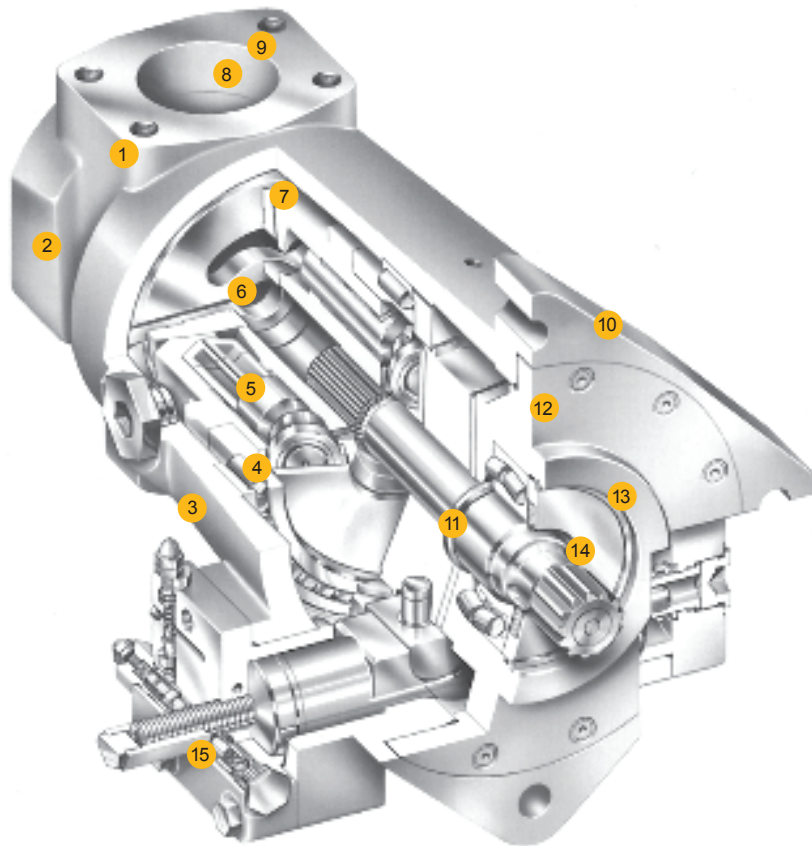

- 1 Highest rated pressure** of any comparable pump available in the market place today.
- 2 Full power through drive capability** allows two (2) pumps of the same displacement to be run in tandem at full rated pressure and flow, simultaneously.
- 3 Fast, compensator** response minimizes pressure overshoot. Two stage, pilot operated compensator provides sharp pressure cutoff at compensator setting, typically regulating pressure within 50 psi (3.5 bar). Compensator may easily be remotely controlled or used in load sensing circuits.
- 4 Precision barrel bearing** absorbs radial forces, allowing longer operation at higher pressure and higher speeds.
- 5 Piston design** minimizes trapped oil volume to maximize efficiency.
- 6 Angled barrel ports** reduce the piston circle diameter, which allows oil to enter at reduced velocity. This allows the pump to run faster, with atmospheric inlet pressure.
- 7 Spherical port plate and barrel face** provides support to barrel to offset forces from angled ports.
- 8 Large suction port** reduces inlet flow velocity to allow the pumps to run at higher speeds with atmospheric inlet.
- 9 Standard SAE split flange with inch or metric bolts, depending on pump version (SAE or metric).**
- 10 Conforms to SAE or ISO mounting standards.**
- 11 Damped low inertia rocker cam** allows very quick compensation, resulting in more stable and quieter pump.
- 12 Heavy duty shaft bearing** to absorb side and thrust loads.
- 13 High pressure shaft seal** allows higher case pressure without external leakage. Note: it is always advisable to maintain the lowest possible case pressure.
- 14 Drive shaft options** include keyed or splined in SAE, ISO and DIN.
- 15 Optional controls** A wide variety of optional controls are available and are designed with simplicity and a maximum of common elements.

Description**GENERAL**

The open loop Premier Series pumps are variable displacement piston pumps with emphasis on superior design with few maintenance requirements. Low inlet velocity requirements allow the pumps to run faster than competitive models without the added expense of boosting the inlet. Modified pistons that reduce the amount of trapped fluid volume result in improved efficiency.

The Premier Series pumps have been designed to operate in a wide range of industries where variable flow, high pressure and/or high speeds are required; such as: presses, construction machinery, injection molding, wood, aircraft, drilling, mining, steel and cranes.

MOUNTING

This pump is designed to operate in any position. For vertical mounting with shaft upward, it is recommended that a 5 psi (0,3 bar) check valve be installed in the case drain port and that the air bleed port (DG on page 36) be connected to the reservoir in order to circulate oil past the shaft bearing. The mounting hub and four bolt mounting flange are in full conformance with SAE/ISO standards. The pump shaft must be in alignment with the shaft of the source driver and should be checked with a dial indicator. The mating pilot bore and coupling must be concentric.

INPUT SHAFT INFORMATION

Splined: The shafts must be aligned within a max. 0.006" , 0,15 mm TIR relative to pilot diameter. Angular misalignment at the external and internal spline axis must be less than $\pm .002$ " per inch , .002 mm per mm radius relative to pilot face. The coupling interface must be lubricated. Parker recommends lithium molydisulfide or similar grease. The internal coupling should be hardened to 27-34 Rc. and must conform to SAE J498B (1971) class 1 flat root side fit, ISO 4156 and DIN 5480.

Keyed: High strength heat treated keys must be used. Replacement keys must be hardened to 27-34 Rc. The key corners must be chamfered .030" - .040", 075 - 1 mm at 45° to clear radii that exist in the keyway. If a flexible coupling is not used, the alignment of keyed shafts must be within tolerances given for splined shafts.

CASE PRESSURE/PLUMBING

The case drain line should be as large as the drain port on the pump. The return to the reservoir must be below the surface of the oil and as far from the suction as possible.

The maximum case pressure is 25 psi (1,7 bar) continuous, 50 psi (3,4 bar) intermittent. Case pressure must never exceed inlet pressure by more than 25 psi (1,7 bar).

When connecting the case drain line, make certain that the drain plumbing passes above the highest point of the pump before returning to the reservoir. If not, install a 5 psi, 0,3 bar case pressure check valve to ensure the case is filled with oil at all times.

All fluid lines, whether pipe, tubing, or hose, must be of adequate size and strength to assure proper operation.

Caution: Do not use galvanized pipe. The coating can flake off with continued use.

MAINTENANCE & SERVICE

Make sure the entire hydraulic system is free of dirt, lint, or other foreign material. This pump is self-lubricating and preventative maintenance is limited to keeping system fluid clean. Do not operate at pressures and speeds in excess of the recommended limit.

For spare parts, reference document numbers, use spare parts manual number HY28-2700-03/PRE/US.

RECOMMENDED FLUIDS

Contact tech support at: pumptechsupport@parker.com

TEMPERATURE

Maximum temperature is limited by the viscosity characteristics of the fluid used. Because high temperatures degrade seals, reduce the service life of the fluid, and create hazards, fluid temperatures should not exceed 180° F, 82° C at the case drain.

FLUID CLEANLINESS

Fluid must be cleaned before adding to the system, and continuously during operation by filters that maintain a cleanliness level of ISO 20/17/14 or better.

code	Shafts	Pumps	05	080	07	110	09	140	12	200	16	260	L1	L2	DIA	K1 x K2	H1	R
02	Keyed SAE44-1 (D&E)		•		•		•	•		•			2.94	1.50	1.7500-1.7494	7/16	1.943	3/8-16 x.65
	Keyed ISO 3019/2 40mm			•		•		•					92	63	40,018-40,002	12 x 8	42,9	M12 x 28
	Keyed ISO 3019/2 50mm							•		•		•	92	38	50,018-50,002	14 x 9	53,4	M10 x 16.5
06	Keyed DIN 6885 40mm			•		•							80	63	40,018-40,002	12 x 8	42,9	M12 x 28
	Keyed DIN 6885 50mm							•		•			92	70	50,018-50,002	14 x 9	53,4	M16 x 32
	Keyed DIN 6885 60mm									•		•	113	100	60,000-60,02	18 x 11	64,0	M20 x 42
03	Splined SAE44-4 (D)		•		•		•						2.94	1.62	side fit, 30°, class 1, 8/16p,13 teeth			3/8-16 x.65
	Splined SAE44-4 (E)								•		•		2.94	1.50	side fit, 30°, class 1, 8/16p,13 teeth			3/8-16 x.65
	Splined ISO 4156 40mm			•		•		•					92	53	side fit, 30°, mod.1,0 - 39 teeth			M10 x 16.5
	Splined ISO 4156 50mm							•		•		•	92	53	side fit, 30°, mod.2,5 - 19 teeth			M10 x 16.5
	Splined DIN 5480 40mm			•		•							55	30	side fit, 30°, mod.2,0 - 18 teeth			M12 x 28
07	Splined DIN 5480 50mm							•		•			65	40	side fit, 30°, mod.2,0 - 24 teeth			M16 x 32
	Splined DIN 5480 60mm									•		•	66	47	side fit, 30°, mod.2,0 - 28 teeth			M20 x 42
	Splined SAE 50-4 (F) Hi-Torque									•			3.44	2.21	side fit, 30°, class 1, 8/16p,15 teeth			3/8-16 x.65

Ports	Ø A/B	Dimensions				Threads		Ports					
		A1	B1	T/U	E	V	D/D1	AG	BG	BG1	C1	DG	
P05	A	2.50	2.00	3.50	4.37	1/2-13 x 1.19	SAE - 8	SAE - 12	SAE - 4	SAE - 4	SAE - 6	SAE - 4	SAE - 4
	B	1.25	1.25	2.63	4.37	1/2-13 x 1.19							
P080	A	64	50,8	88,9	111,1	M12 x 30,2	3/8 BSPP	3/4 BSPP	1/4 BSPP	1/4 BSPP	1/4 BSPP	1/4 BSPP	3/8 BSPP
	B	32	31,8	66,7	111,1	M14 x 50							
P07	A	3.00	2.44	4.19	4.37	5/8-11 x 1.19	SAE - 8	SAE - 16	SAE - 4	SAE - 6	SAE - 6	SAE - 4	SAE - 4
	B	1.25	1.25	2.63	4.52	1/2-13 x 1.19							
P110	A	76	61,9	106,4	111,1	M16 x 38,1	3/8 BSPP	1 BSPP	1/4 BSPP	1/4 BSPP	1/4 BSPP	1/4 BSPP	1/4 BSPP
	B	32	31,8	66,7	114,9	M14 x 50							
P09	A	3.00	2.44	4.19	4.50	5/8-11 x 1.50	SAE - 8	SAE - 20	SAE - 4	SAE - 4	SAE - 6	SAE - 4	SAE - 4
	B	1.50	1.44	3.13	4.83	5/8-11 x 1.50							
P140	A	76	61,9	106,4	114,3	M16 x 38,1	3/8 BSPP	1-1/2 BSPP	1/4 BSPP	1/4 BSPP	1/4 BSPP	1/4 BSPP	1/8 BSPP
	B	38	36,5	79,37	122,7	M16 x 38,1							
P12	A	3.50	2.76	4.75	4.50	5/8-11 x 1.38	SAE - 8	SAE - 24	SAE - 4	SAE - 6	SAE - 6	SAE - 4	SAE - 4
	B	1.50	1.44	3.13	5,37	5/8-11 x 1.50							
P200	A	89	70,0	120,65	114,3	M16 x 38,1	3/8 BSPP	1-1/2 BSPP	1/4 BSPP	1/4 BSPP	1/4 BSPP	1/4 BSPP	1/4 BSPP
	B	38	36,5	79,37	136,4								
P16	A	3.50	2.76	4.75	4.50	5/8-11 x 1.38	SAE - 8	SAE - 24	SAE - 4	SAE - 6	SAE - 6	SAE - 4	SAE - 4
	B	1.50	1.44	3.13	5.50	5/8-11 x 1.38							
P260	A	89	70,0	120,65	114,3	M16 x 38,1	3/8 BSPP	1-1/2 BSPP	1/4 BSPP	1/4 BSPP	1/4 BSPP	1/4 BSPP	1/4 BSPP
	B	38	36,5	79,37	146,0	M16 x 38,1							

NOTE: For port identification see page 40.

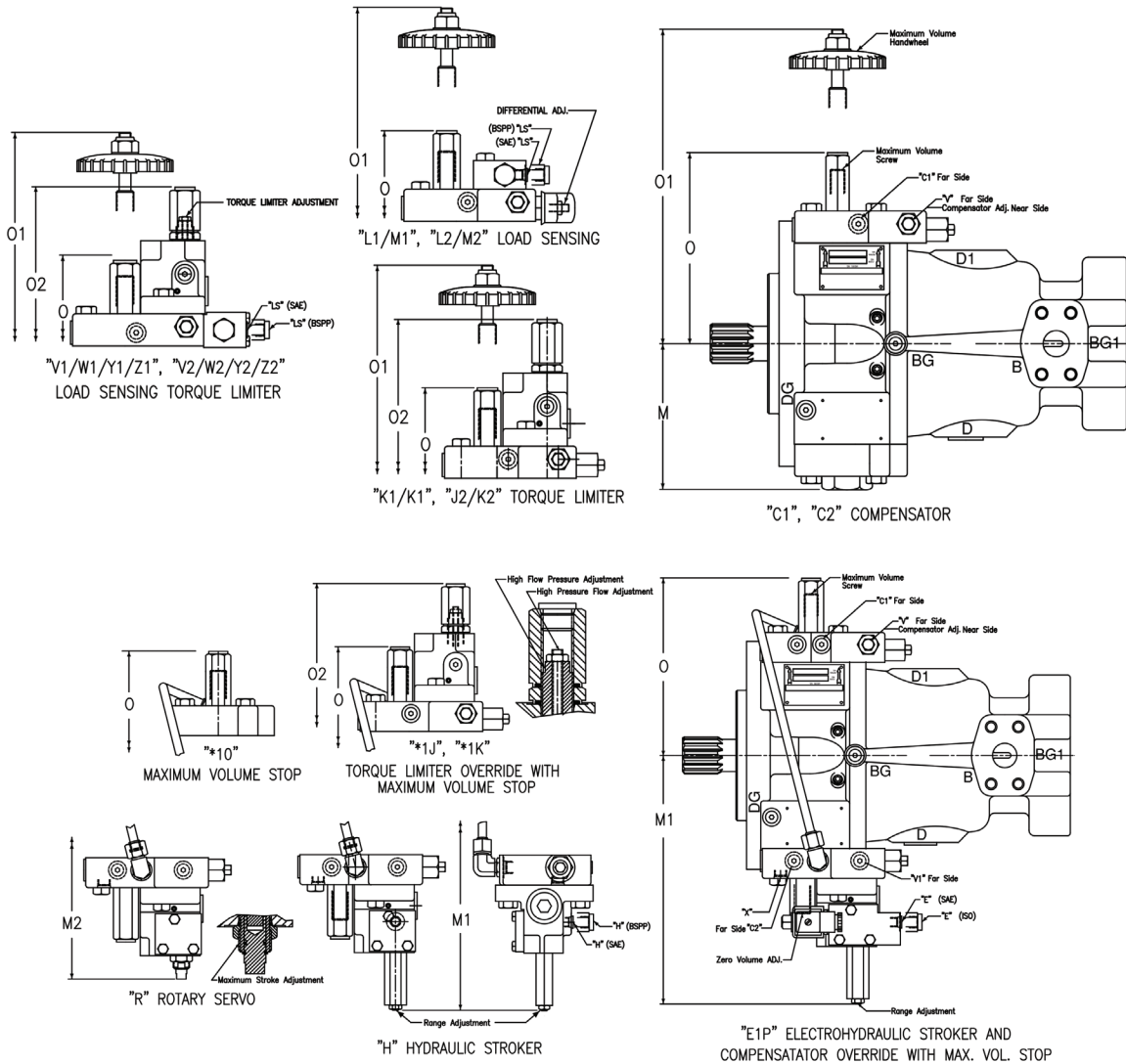

COUNTER-CLOCKWISE ROTATION SHOWN

For clockwise rotation, the top and bottom control caps are interchanged.

	"C1"	"C2"	"E"	"H"	"R"	"V"	"V1"	"X"	M	M1	M2	O	O1	O2
P05	SAE-4	SAE-4	SAE-4	SAE-4	SAE-4	SAE-8	SAE-4	SAE-6	6.23	10.09	9.87	8.16	13.44	11.08
P080	1/4" BSPP	1/4" BSPP	1/4" BSPP	1/4" BSPP	1/4" BSPP	3/8" BSPP	1/4" BSPP	3/8" BSPP	158,2	256,2	250,8	207,3	341,3	281,4
P07	SAE-4	SAE-4	SAE-4	SAE-4	SAE-4	SAE-8	SAE-4	SAE-6	6.26	10.15	9.93	8.22	13.48	11.14
P110	1/4" BSPP	1/4" BSPP	1/4" BSPP	1/4" BSPP	1/4" BSPP	3/8" BSPP	1/4" BSPP	3/8" BSPP	159,2	257,8	252,4	208,8	342,4	282,9
P09	SAE-4	SAE-4	SAE-4	SAE-4	SAE-4	SAE-8	SAE-4	SAE-8	6.79	12.21	10.63	8.72	14.19	11.84
P140	1/4" BSPP	1/4" BSPP	1/4" BSPP	1/4" BSPP	1/4" BSPP	3/8" BSPP	1/4" BSPP	3/8" BSPP	172,3	310,1	270,0	221,5	360,4	300,7
P12	SAE-4	SAE-4	SAE-4	SAE-4	SAE-4	SAE-8	SAE-4	SAE-8	6.92	12.34	10.76	8.85	14.32	11.97
P200	1/4" BSPP	1/4" BSPP	1/4" BSPP	1/4" BSPP	1/4" BSPP	3/8" BSPP	1/4" BSPP	3/8" BSPP	175,8	313,4	273,3	224,8	363,7	304,0
P16	SAE-4	SAE-4	SAE-4	SAE-4	SAE-4	SAE-8	SAE-4	SAE-8	7.29	12.6	11.02	9.11	14.58	12.23
P260	1/4" BSPP	1/4" BSPP	1/4" BSPP	1/4" BSPP	1/4" BSPP	3/8" BSPP	1/4" BSPP	3/8" BSPP	185,2	320	279,9	231,4	370,3	310,6

Items in **bold** are SAE version and inches.
Italic dimensions are in millimeters.

NOTE: For more detail information refer to the individual pump installation drawings. These are available on CD. Contact your nearest sales representative or distributor.



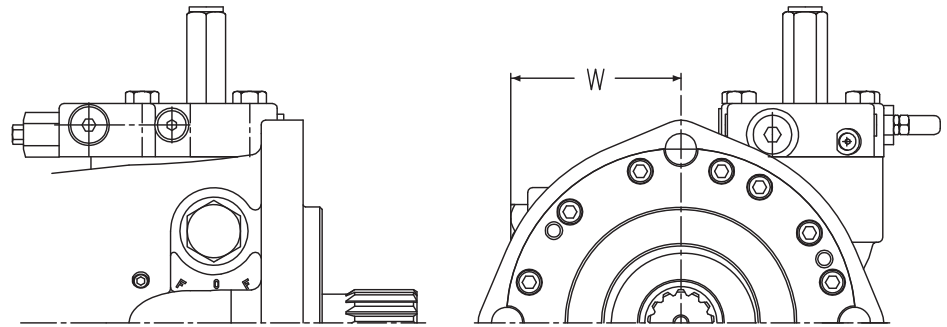

NO STROKE INDICATOR

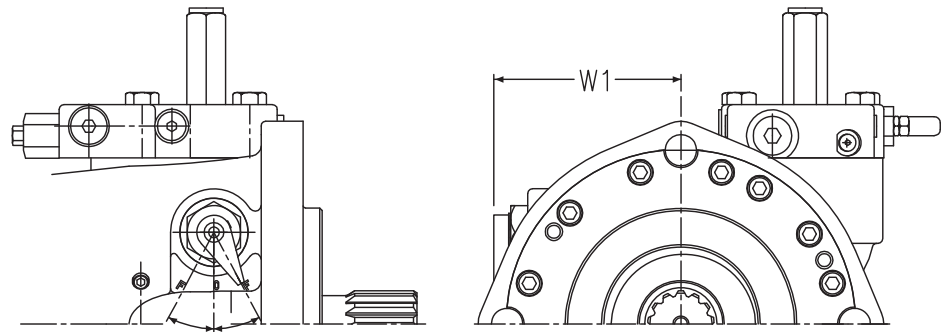

INDICATOR

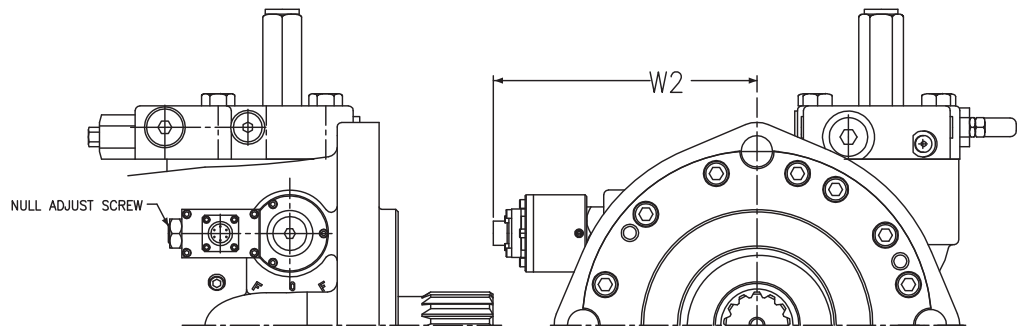
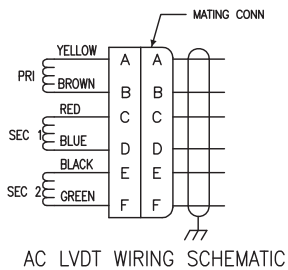

AC LVDT

	P05/P080	P07/P110	P09/P140	P12/P200	P16/P260
W	4.25/(107,8)	4.41/(111,9)	5.07/(128,7)	4.90/(124,4)	5.07/(128,7)
W1	4.68/(118,9)	4.84/(123,0)	5.50/(139,8)	5.33/(135,5)	5.50/(139,8)
W2	6.66/(169,3)	6.82/(173,3)	6.89/(175,1)	7.31/(185,8)	7.48/(190,1)

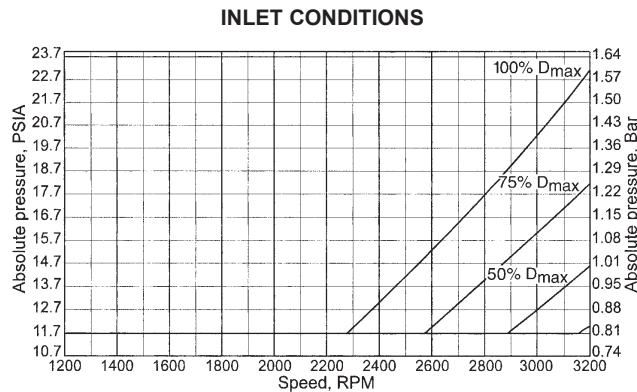
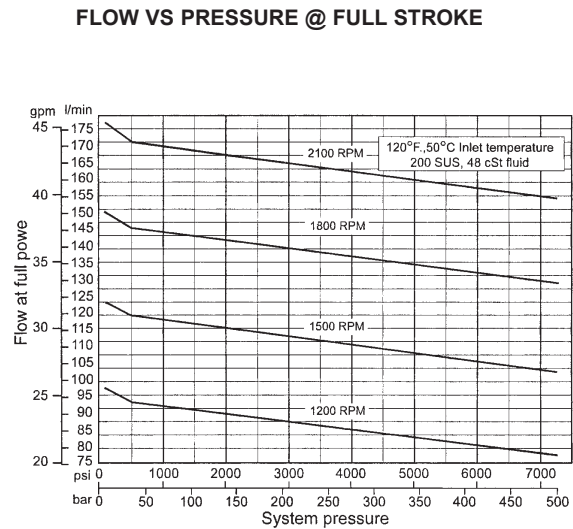
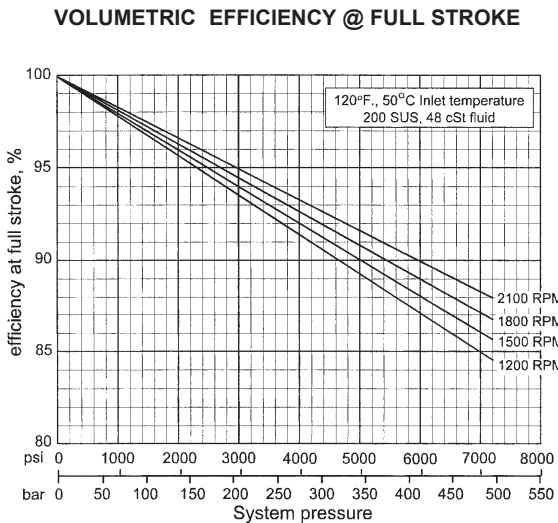
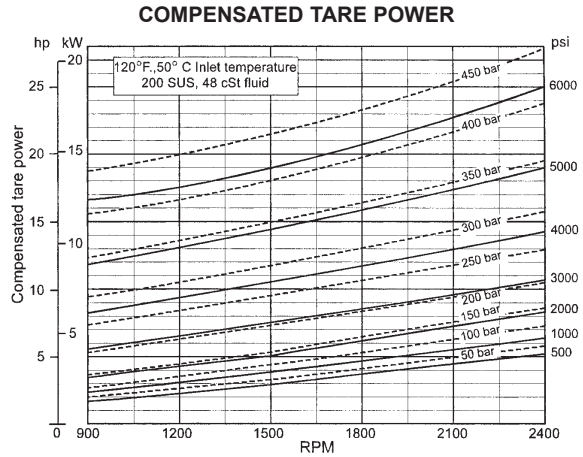
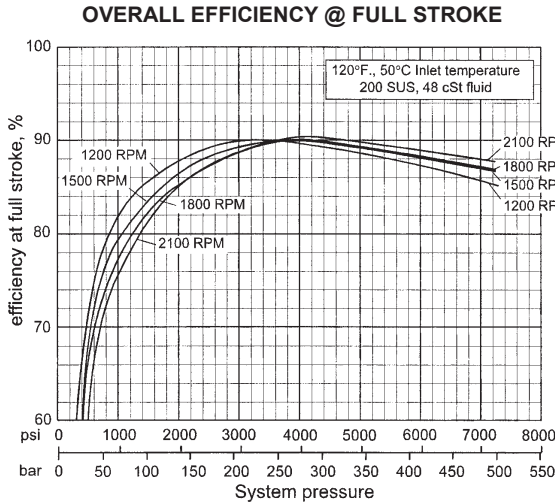

Note: The absolute inlet pressure is the pressure required to fill the pump with petroleum based fluids. The maximum pressure in the inlet port is 200 psi, 14 bar. For unboosted systems, the diameter of the suction line must be sized to allow a maximum velocity not higher than 4 ft/sec., 1.22 m/sec. A coarse screen may be considered in the suction line, no filter. For water in oil invert emulsions and water glycols increase the inlet absolute pressure by 25%, for phosphate ester increase the absolute inlet pressure by 35%. Any inlet pressures above atmospheric may increase noise levels and decrease efficiencies noted in this literature. Please consult your nearest Parker Office for further details.



SOUND PRESSURE LEVEL (dBA) @ FULL STROKE

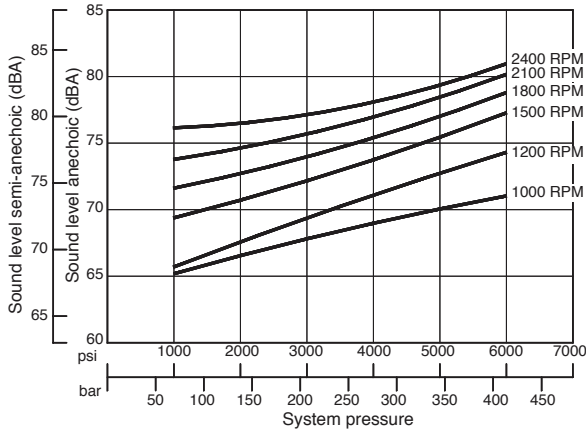

SOUND PRESSURE LEVEL (dBA) COMPENSATED

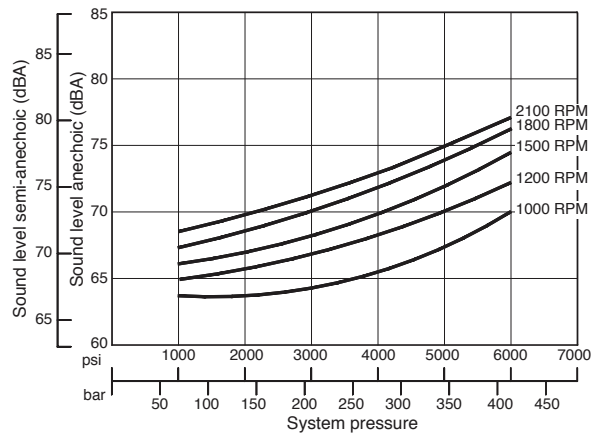

Note: Pump acoustical data was determined in accordance with ANSI/B93.71M, Hydraulic Fluid Power Pumps test code for the determination of airborne noise levels. Semi-anechoic values are presented according to the standard. Anechoic values are calculated for comparison with DIN 45635, part 1. The DIN standards measures sound levels over different surface areas so comparisons are not exact.

HYDRAULIC STROKER

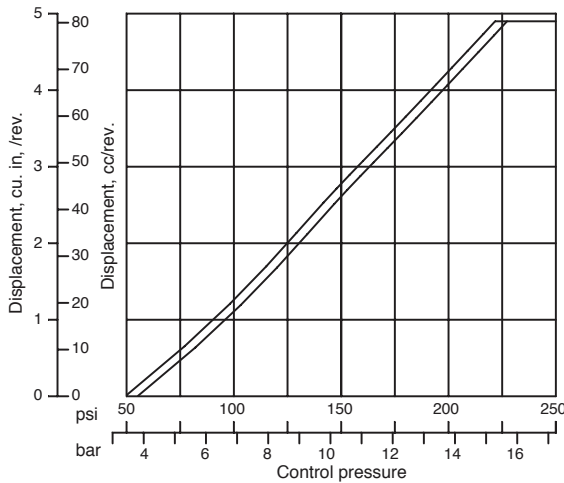

ELECTROHYDRAULIC STROKER (24 VOLT)

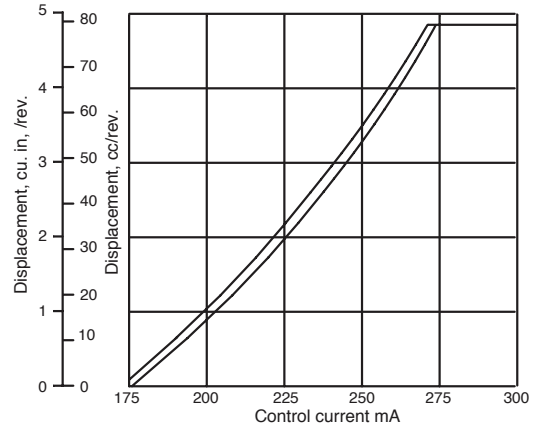

STROKER RESPONSE VS SERVO PRESSURE, SERVO FLOW*

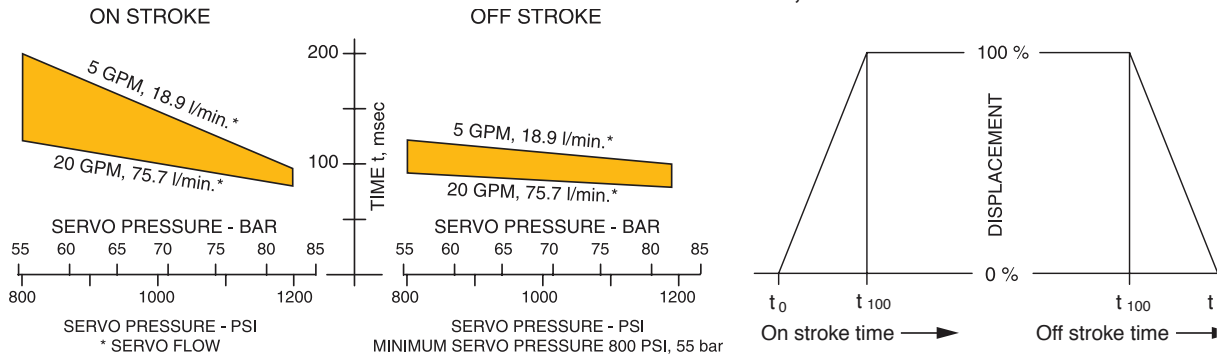

OVERALL EFFICIENCY @ FULL STROKE

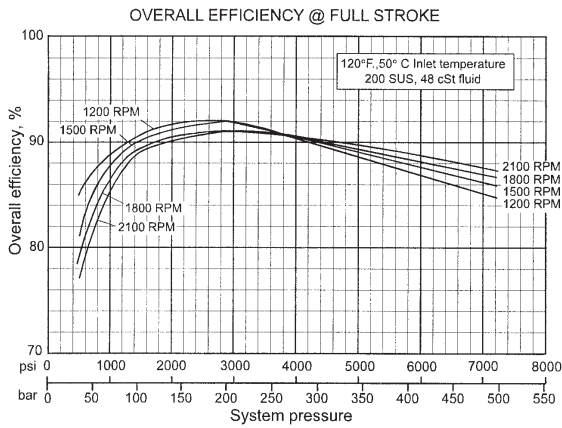

COMPENSATED TARE POWER

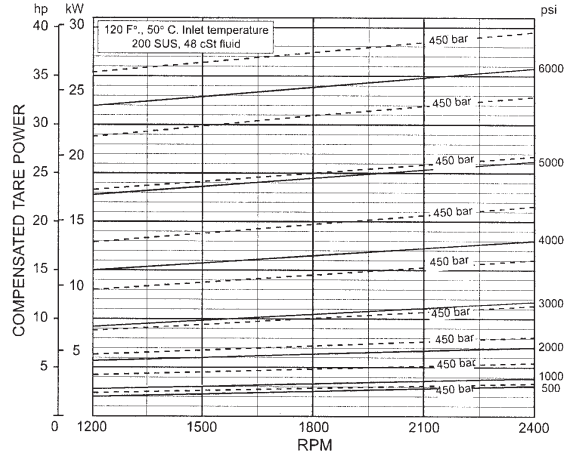

VOLUMETRIC EFFICIENCY @ FULL STROKE

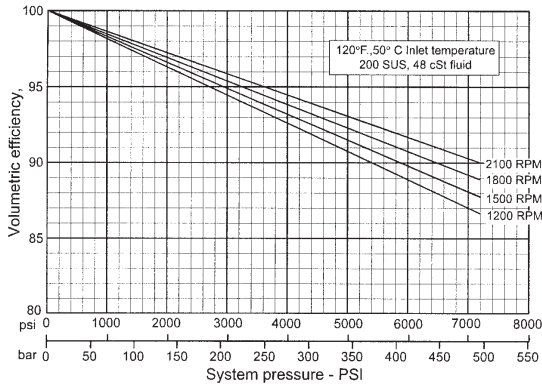

FLOW VS PRESSURE @ FULL STROKE

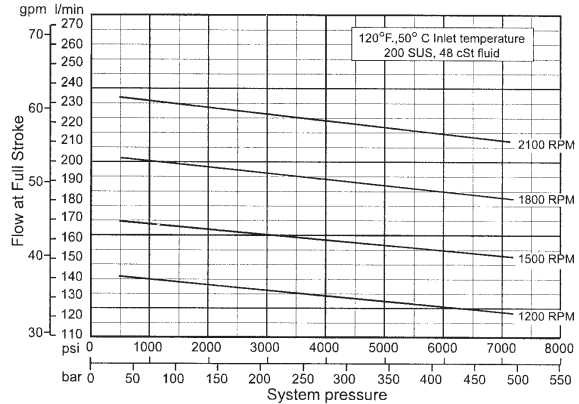

INLET CONDITIONS

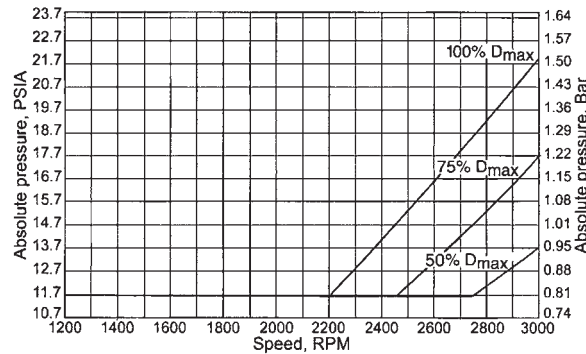

Note: The absolute inlet pressure is the pressure required to fill the pump with petroleum based fluids. The maximum pressure in the inlet port is 200 psi, 14 bar. For unboosted systems, the diameter of the suction line must be sized to allow a maximum velocity not higher than 4 ft/sec., 1.22 m/sec. A coarse screen may be considered in the suction line, no filter. For water in oil invert emulsions and water glycols increase the inlet absolute pressure by 25%, for phosphate ester increase the absolute inlet pressure by 35%. Any inlet pressures above atmospheric may increase noise levels and decrease efficiencies noted in this literature. Please consult your nearest Parker Office for further details.

SOUND PRESSURE LEVEL (dBA) @ FULL STROKE

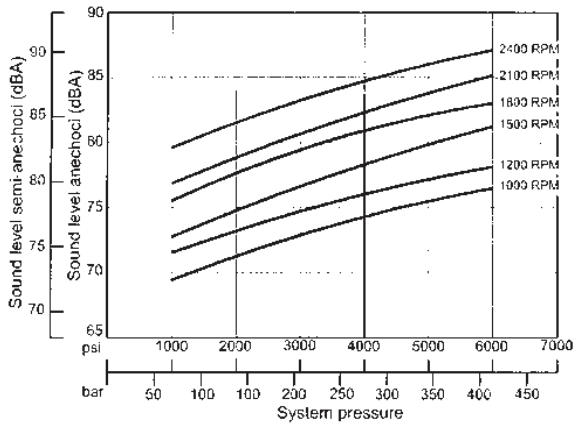

SOUND PRESSURE LEVEL (dBA) COMPENSATED

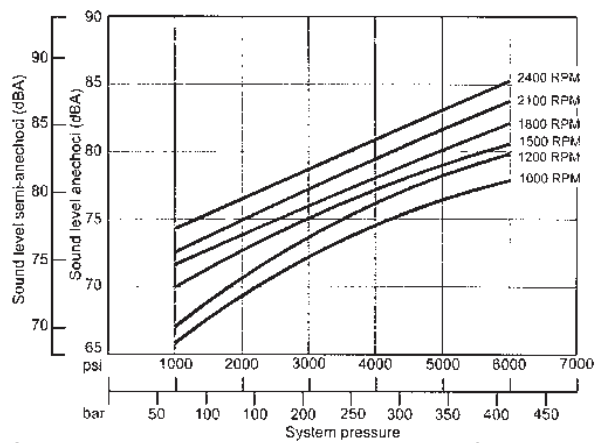

Note: Pump acoustical data was determined in accordance with ANSI/B93.71M, Hydraulic Fluid Power Pumps test code for the determination of airborne noise levels. Semi-anechoic values are presented according to the standard. Anechoic values are calculated for comparison with DIN 45635, part 1. The DIN standards measures sound levels over different surface areas so comparisons are not exact.

HYDRAULIC STROKER

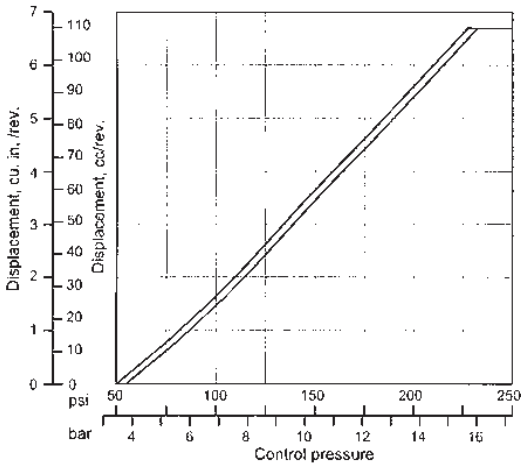

ELECTROHYDRAULIC STROKER (24 VOLT)

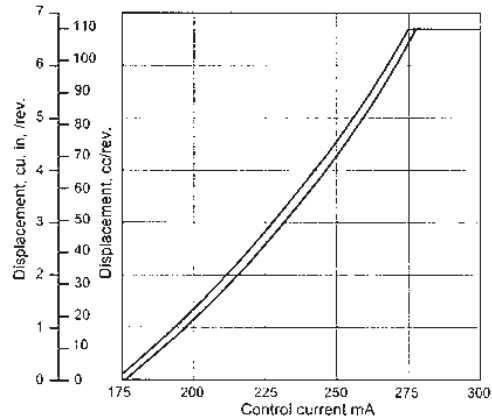

STROKER RESPONSE VS SERVO PRESSURE, SERVO FLOW* (see note on page 11)

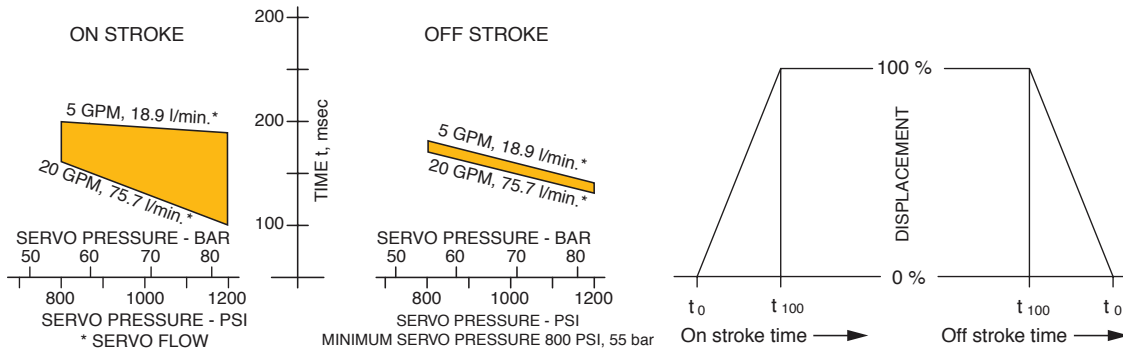

OVERALL EFFICIENCY @ FULL STROKE

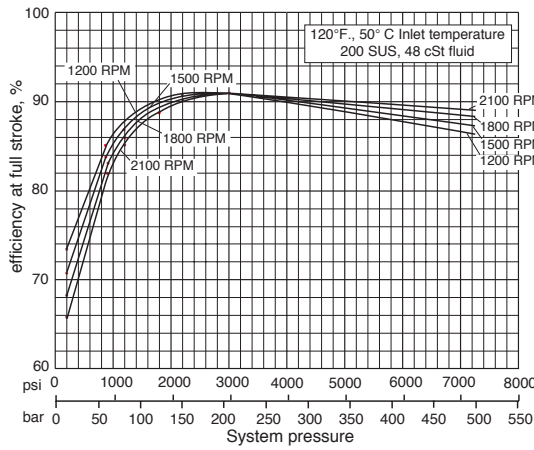

COMPENSATED TARE POWER

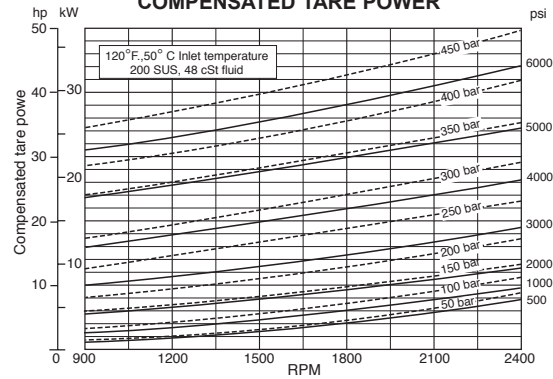

VOLUMETRIC EFFICIENCY @ FULL STROKE

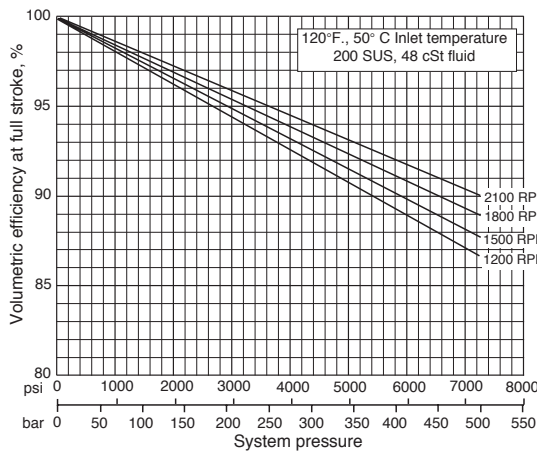

FLOW VS PRESSURE @ FULL STROKE

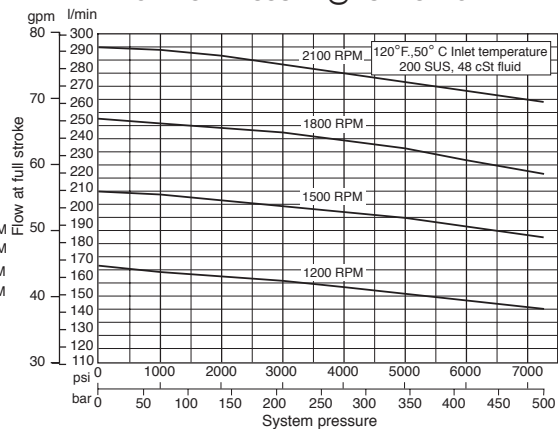

INLET CONDITIONS

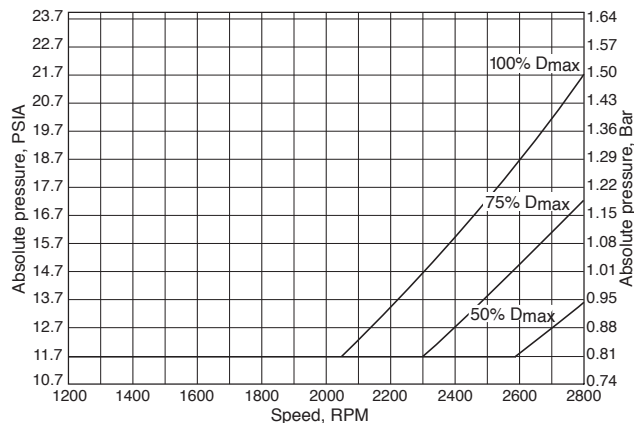

Note: The absolute inlet pressure is the pressure required to fill the pump with petroleum based fluids. The maximum pressure in the inlet port is 200 psi, 14 bar. For unboosted systems, the diameter of the suction line must be sized to allow a maximum velocity not higher than 4 ft/sec., 1,22 m/sec. A coarse screen may be considered in the suction line, no filter. For water in oil invert emulsions and water glycols increase the inlet absolute pressure by 25%, for phosphate ester increase the absolute inlet pressure by 35%. Any inlet pressures above atmospheric may increase noise levels and decrease efficiencies noted in this literature. Please consult your nearest Parker Office for further details.



SOUND PRESSURE LEVEL (dBA) @ FULL STROKE

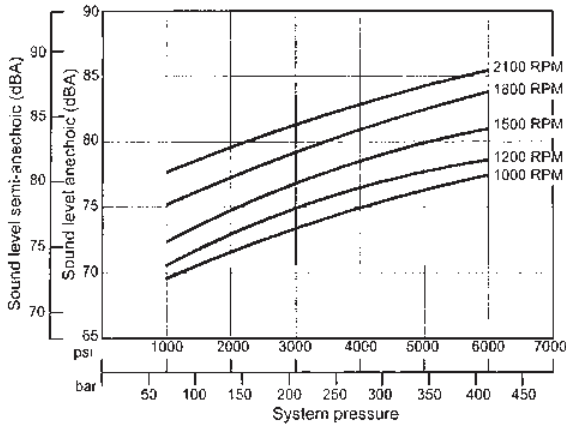

SOUND PRESSURE LEVEL (dBA) COMPENSATED

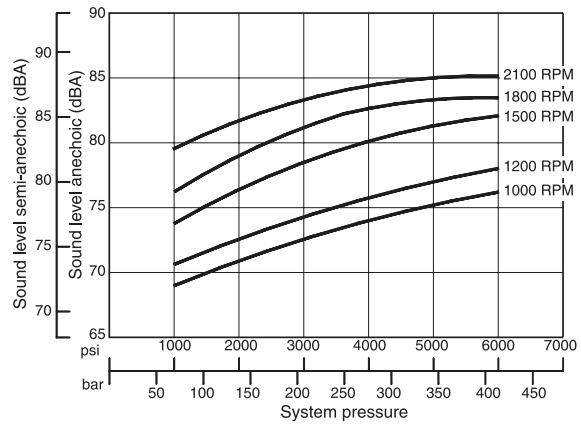

Note: Pump acoustical data was determined in accordance with ANSI/B93.71M, Hydraulic Fluid Power Pumps test code for the determination of airborne noise levels. Semi-anechoic values are presented according to the standard. Anechoic values are calculated for comparison with DIN 45635, part 1. The DIN standards measures sound levels over different surface areas so comparisons are not exact.

HYDRAULIC STROKER

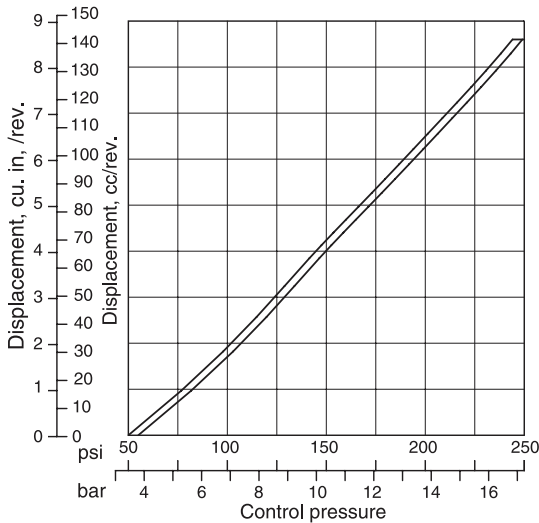

ELECTROHYDRAULIC STROKER (24 VOLT)

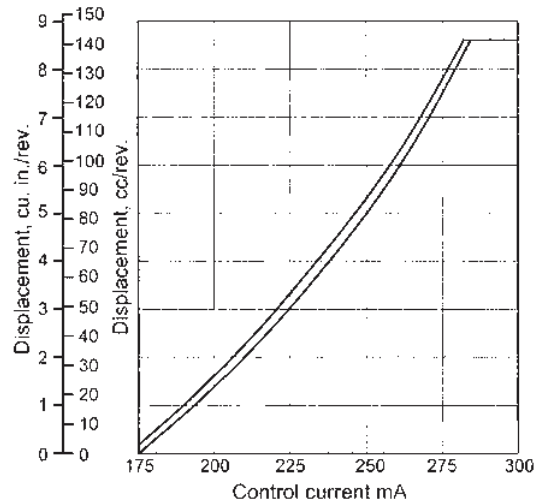

STROKER RESPONSE VS SERVO PRESSURE, SERVO FLOW* (see note on page 11)

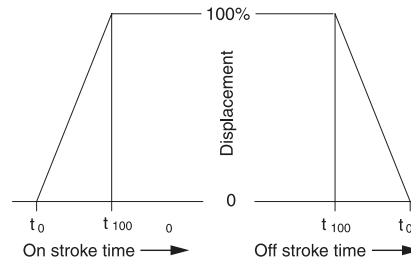
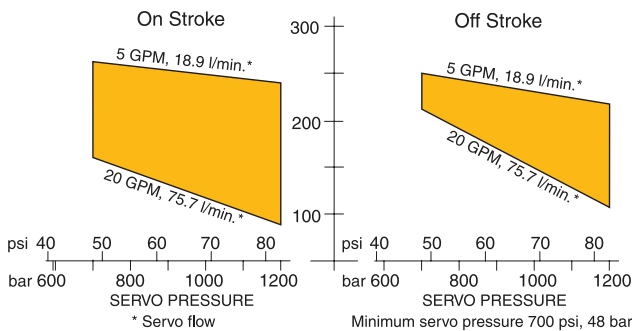

OVERALL EFFICIENCY @ FULL STROKE

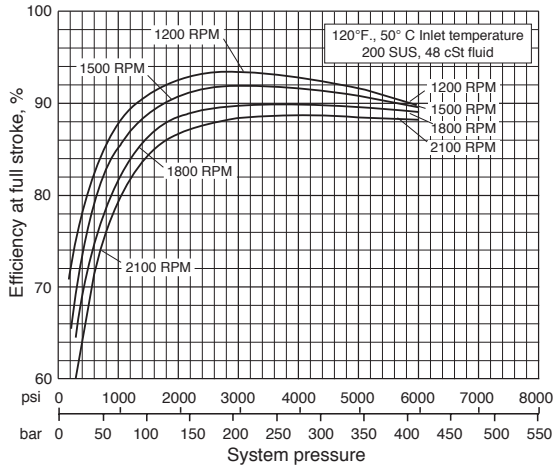

COMPENSATED TARE POWER

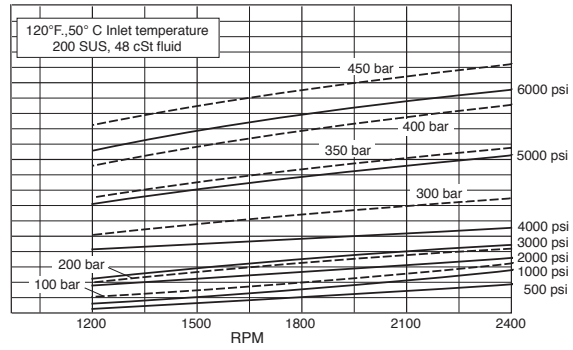

VOLUMETRIC EFFICIENCY @ FULL STROKE

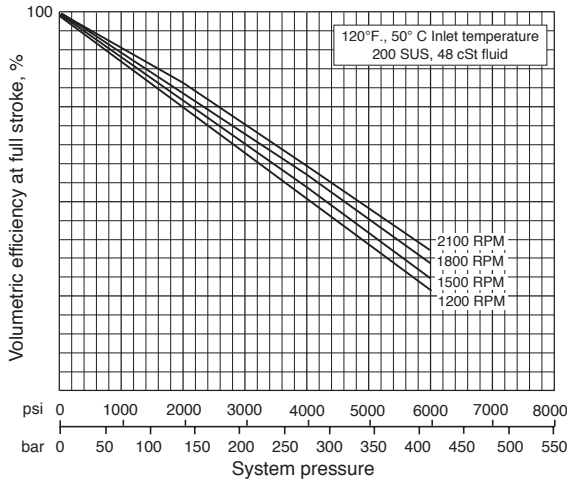

FLOW VS PRESSURE @ FULL STROKE

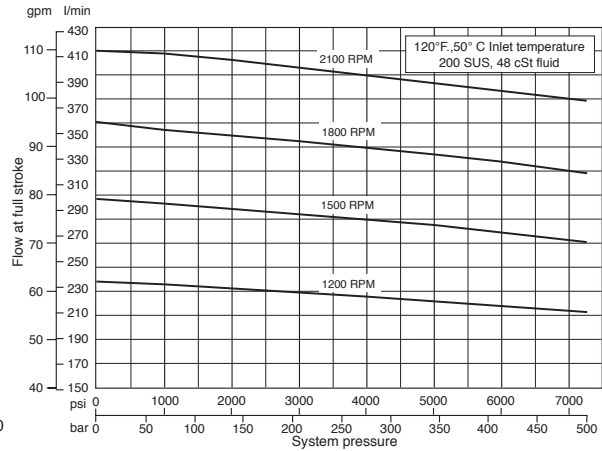

INLET CONDITIONS

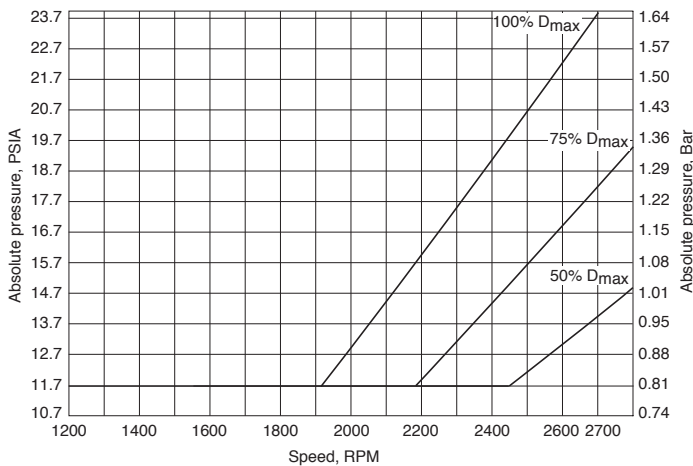

Note: The absolute inlet pressure is the pressure required to fill the pump with petroleum based fluids. The maximum pressure in the inlet port is 200 psi, 14 bar. For unboosted systems, the diameter of the suction line must be sized to allow a maximum velocity not higher than 4 ft/sec., 1.22 m/sec. A coarse screen may be considered in the suction line, no filter. For water in oil invert emulsions and water glycols increase the inlet absolute pressure by 25%, for phosphate ester increase the absolute inlet pressure by 35%. Any inlet pressures above atmospheric may increase noise levels and decrease efficiencies noted in this literature. Please consult your nearest Parker Office for further details.

SOUND PRESSURE LEVEL (dBA) @ FULL STROKE

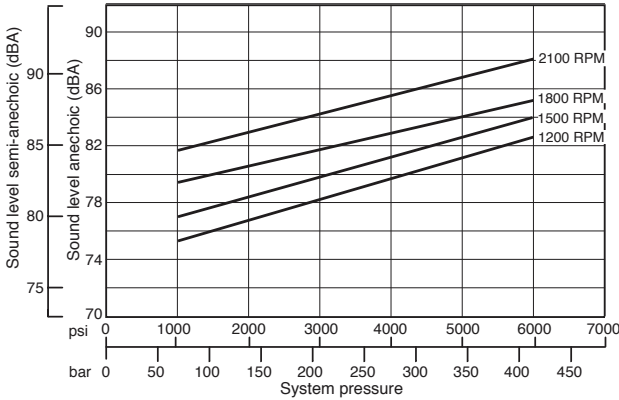

SOUND PRESSURE LEVEL (dBA) COMPENSATED

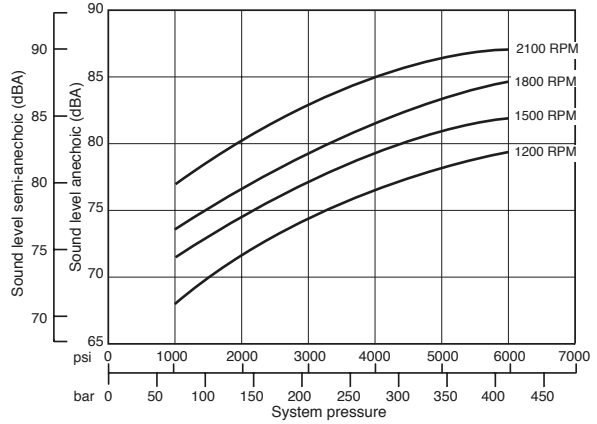

Note: Pump acoustical data was determined in accordance with ANSI/B93.71M, Hydraulic Fluid Power Pumps test code for the determination of airborne noise levels. Semi-anechoic values are presented according to the standard. Anechoic values are calculated for comparison with DIN 45635, part 1. The DIN standards measures sound levels over different surface areas so comparisons are not exact.

HYDRAULIC STROKER

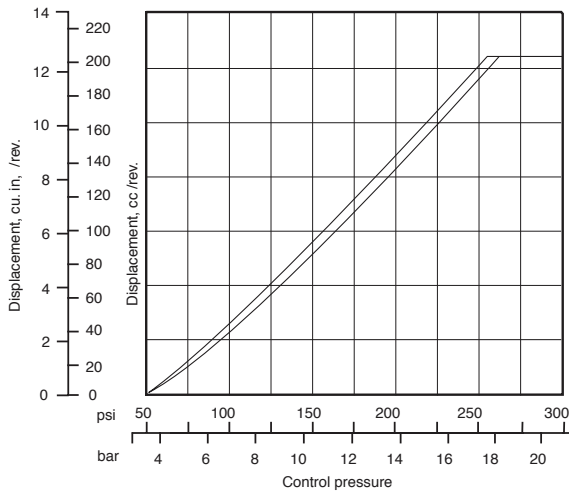

ELECTROHYDRAULIC STROKER (24 VOLT)

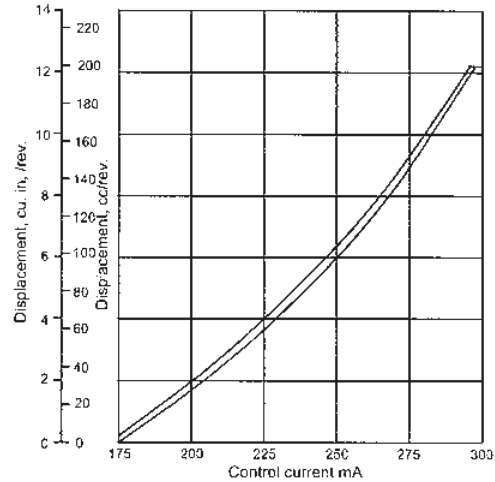

STROKER RESPONSE VS SERVO PRESSURE, SERVO FLOW* (see note on page 11)

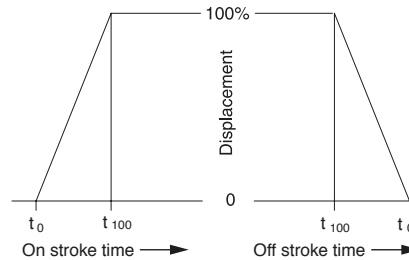
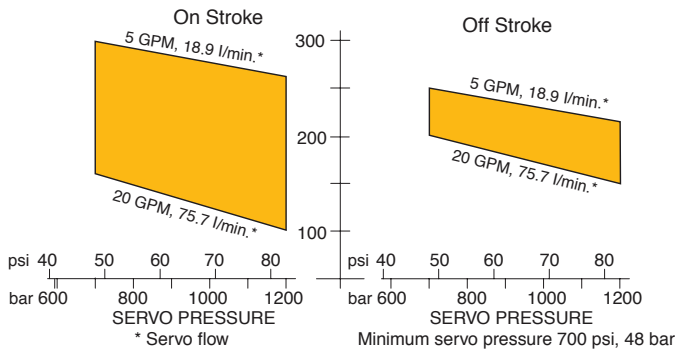

OVERALL EFFICIENCY @ FULL STROKE

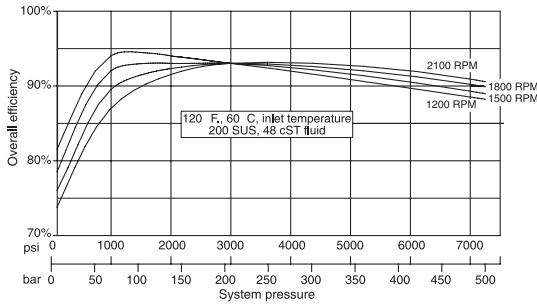

COMPENSATED TARE POWER

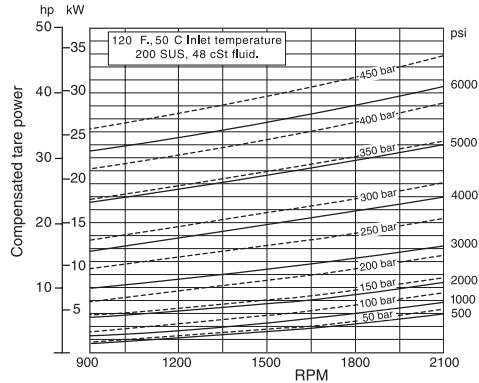

VOLUMETRIC EFFICIENCY @ FULL STROKE

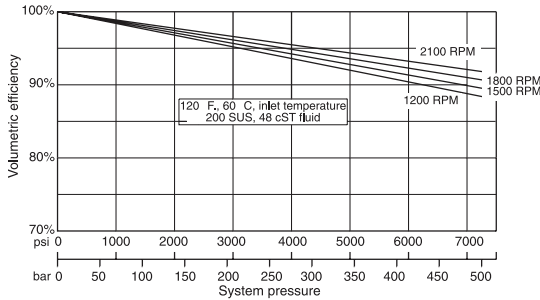

FLOW VS PRESSURE @ FULL STROKE

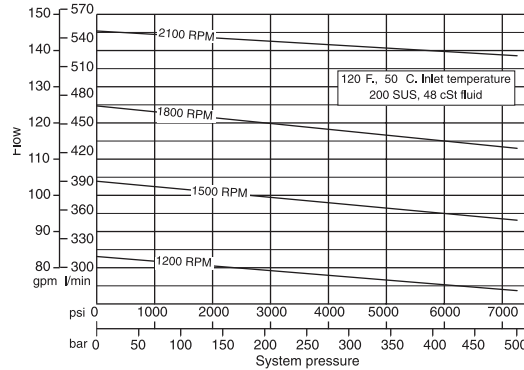

INLET CONDITIONS

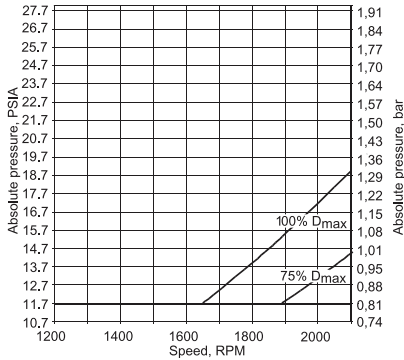

Note: The absolute inlet pressure is the pressure required to fill the pump with petroleum based fluids. The maximum pressure in the inlet port is 200 psi, 14 bar. For unboosted systems, the diameter of the suction line must be sized to allow a maximum velocity not higher than 4 ft/sec., 1.22 m/sec. A coarse screen may be considered in the suction line, no filter. For water in oil invert emulsions and water glycols increase the inlet absolute pressure by 25%, for phosphate ester increase the absolute inlet pressure by 35%. Any inlet pressures above atmospheric may increase noise levels and decrease efficiencies noted in this literature. Please consult your nearest Parker Office for further details.

STROKER RESPONSE VS SERVO PRESSURE, SERVO FLOW* (see note on page 11)

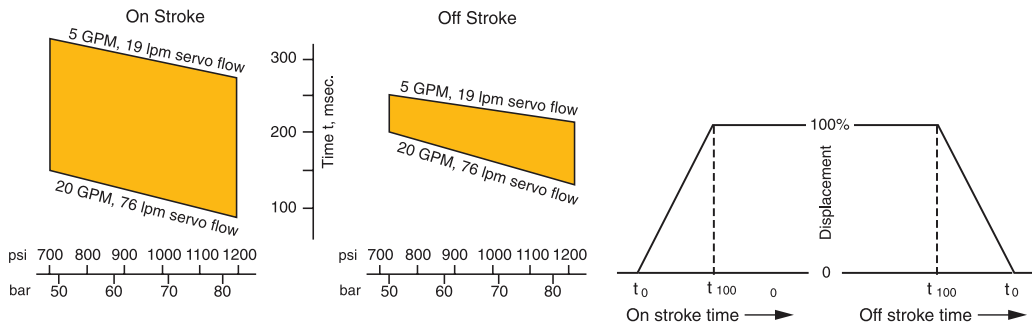

**SOUND PRESSURE LEVEL (dBA) @ FULL STROKE
P16 H**

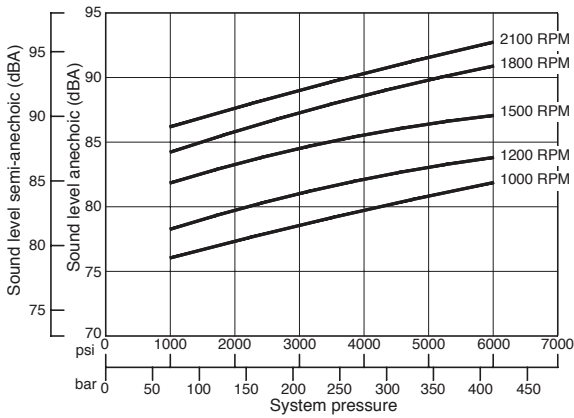

**SOUND PRESSURE LEVEL (dBA) COMPENSATED
P16H**

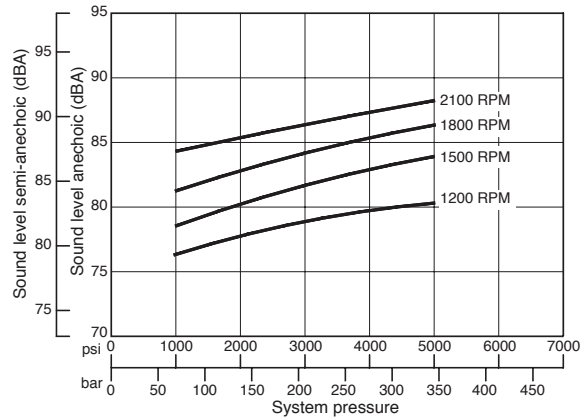

**SOUND PRESSURE LEVEL (dBA) @ FULL STROKE
P16Q**

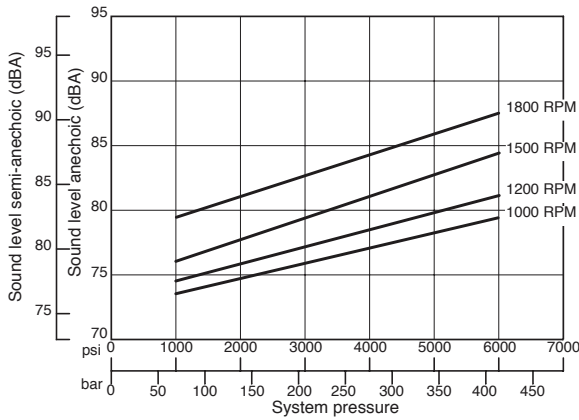

**SOUND PRESSURE LEVEL (dBA) COMPENSATED
P16Q**

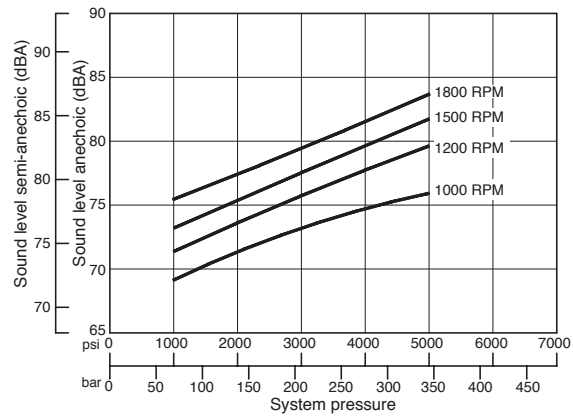

HYDRAULIC STROKER

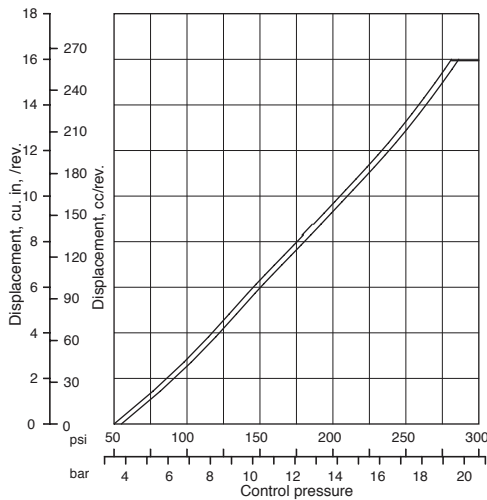

ELECTROHYDRAULIC STROKER (24 VOLT)

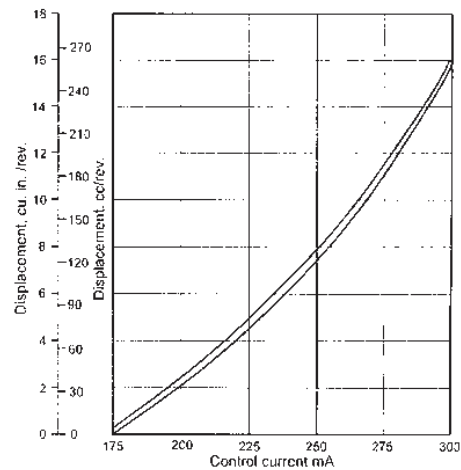

**SAE REAR AUX. MTG. ADAPTORS FOR ALL PREMIER SERIES
 SAE**

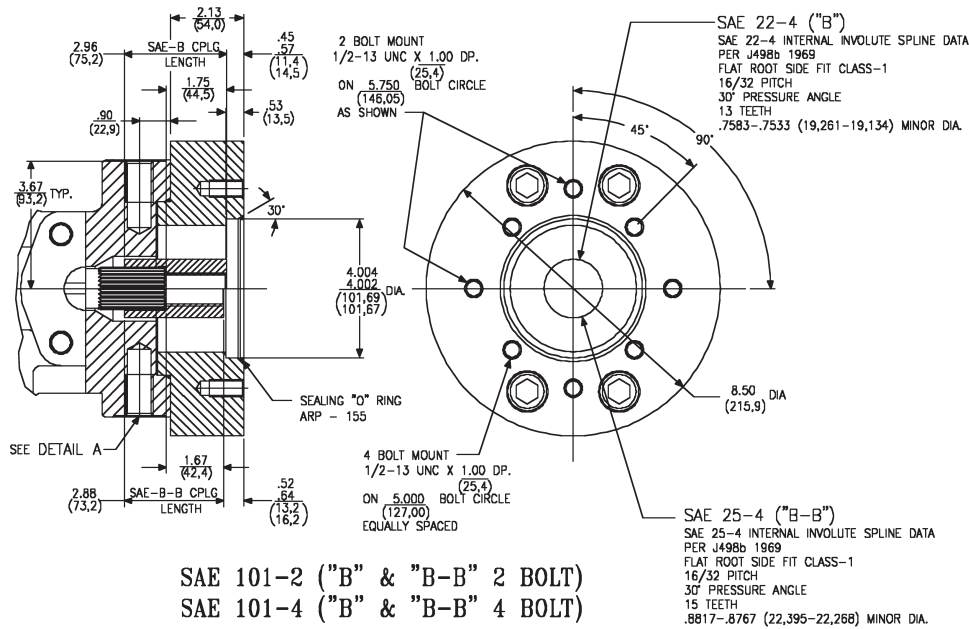
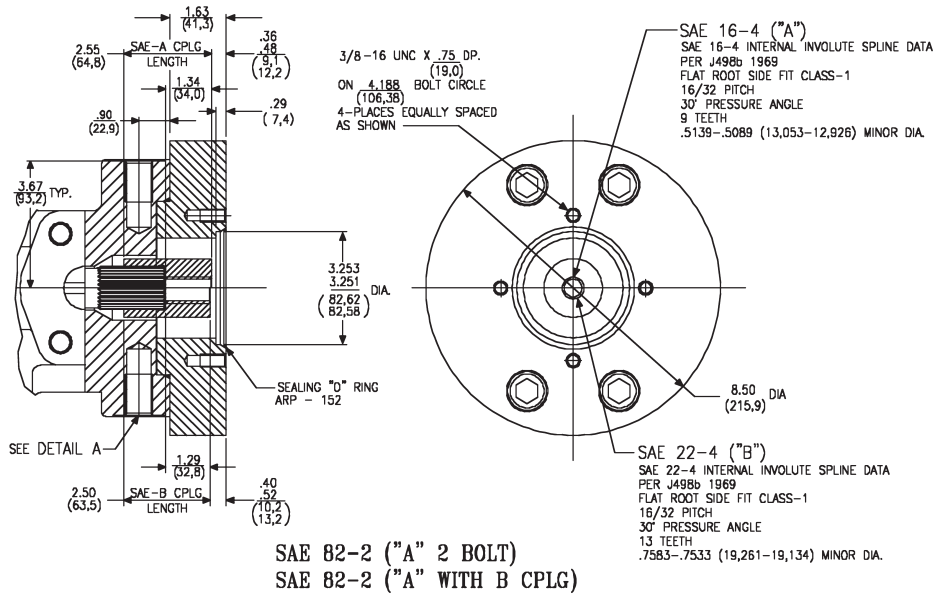

**SAE REAR AUX. MTG. ADAPTORS FOR ALL PREMIER SERIES
 SAE**

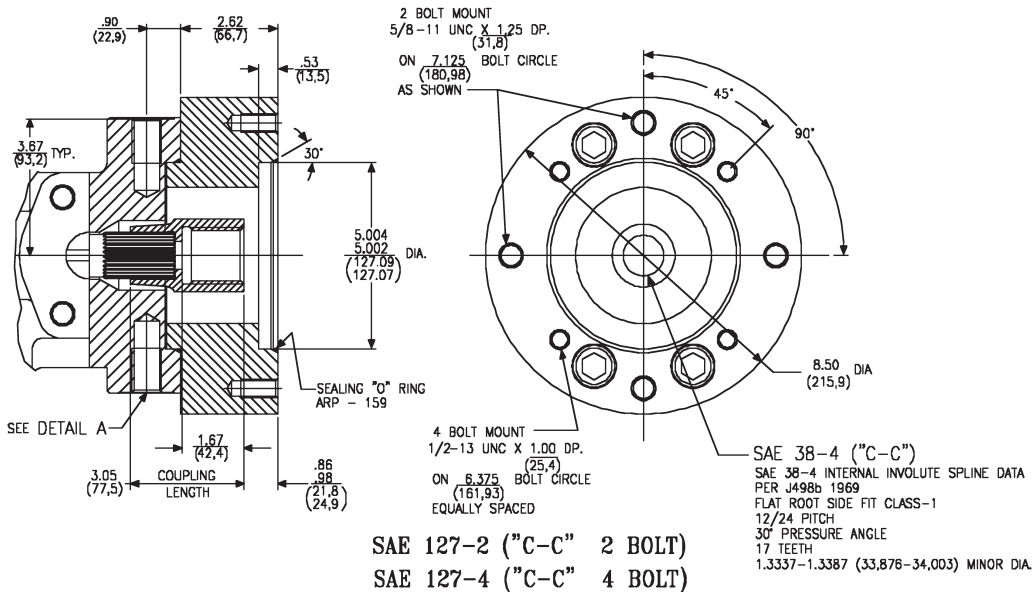
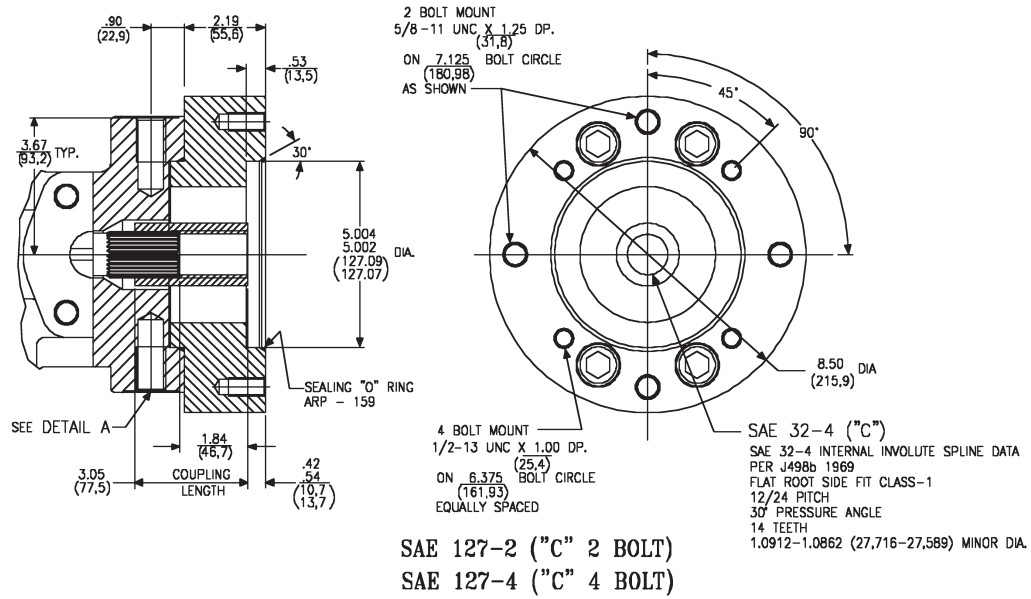

**SAE REAR AUX. MTG. ADAPTORS FOR ALL PREMIER SERIES
 SAE**

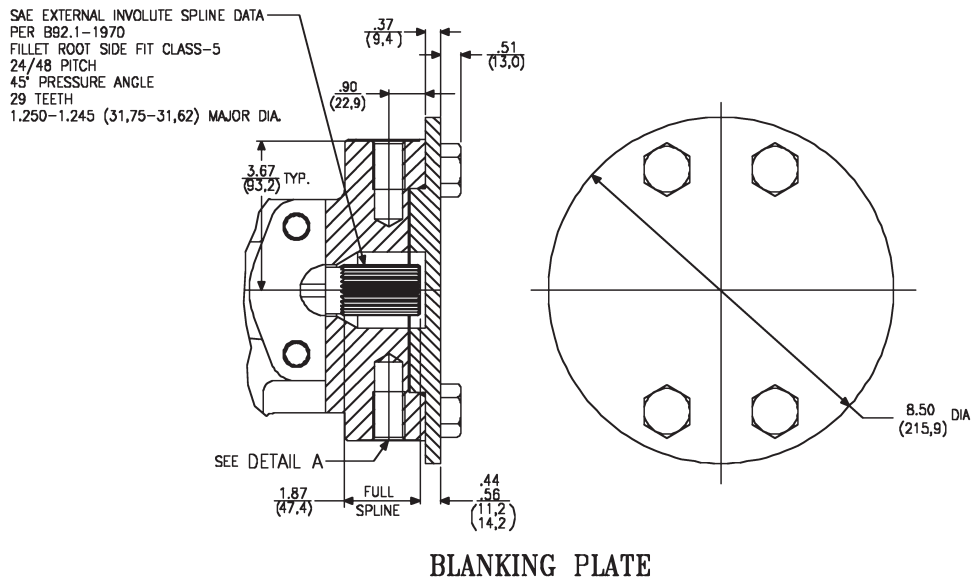
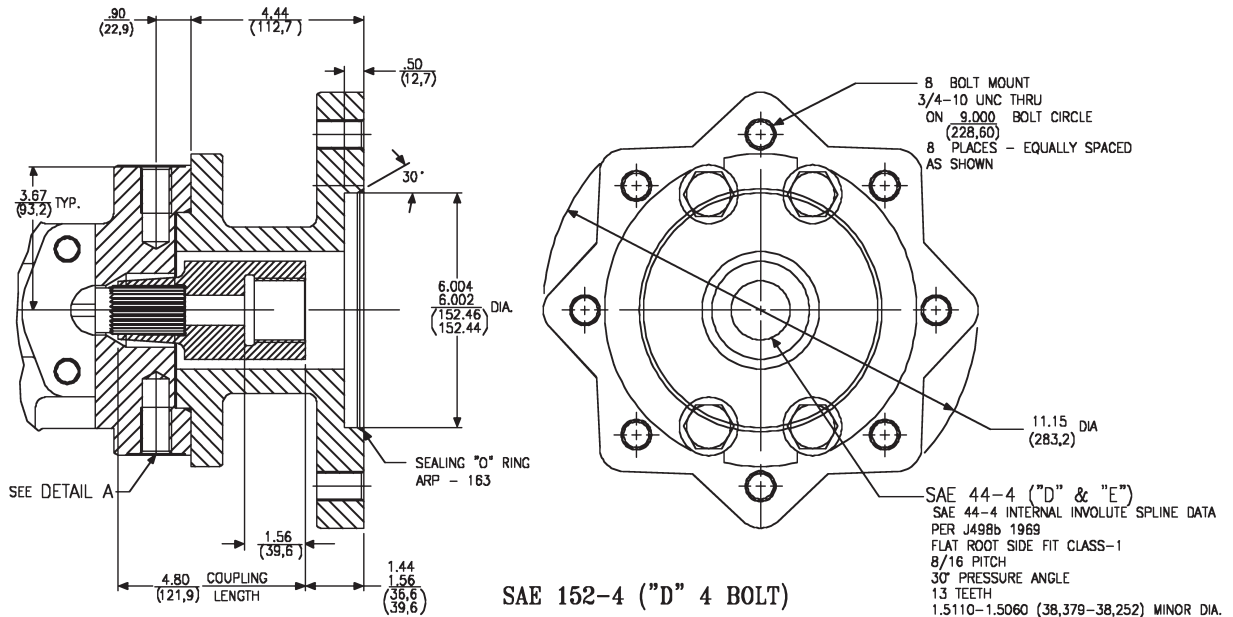

**SAE REAR AUX. MTG. ADAPTORS FOR ALL PREMIER SERIES
 SAE**

FOR P16 AND P260 ONLY

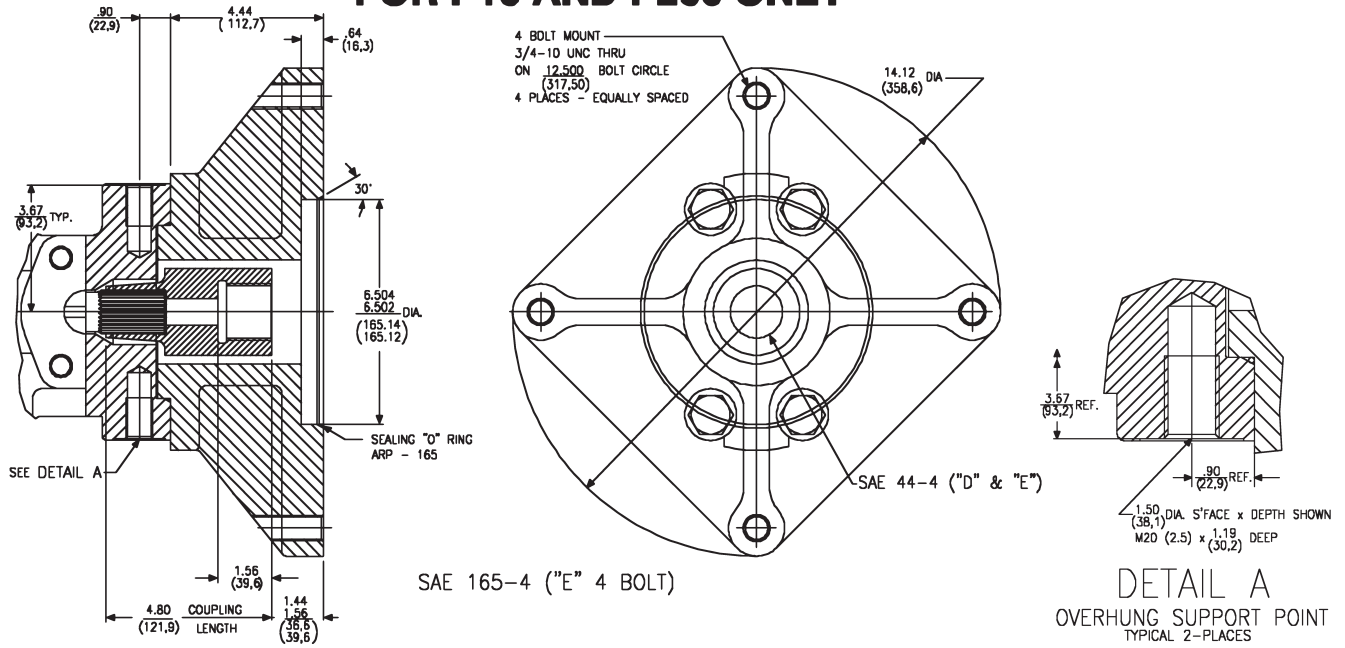

ISO REAR AUX. MTG. ADAPTORS FOR ALL PREMIER SERIES
ISO

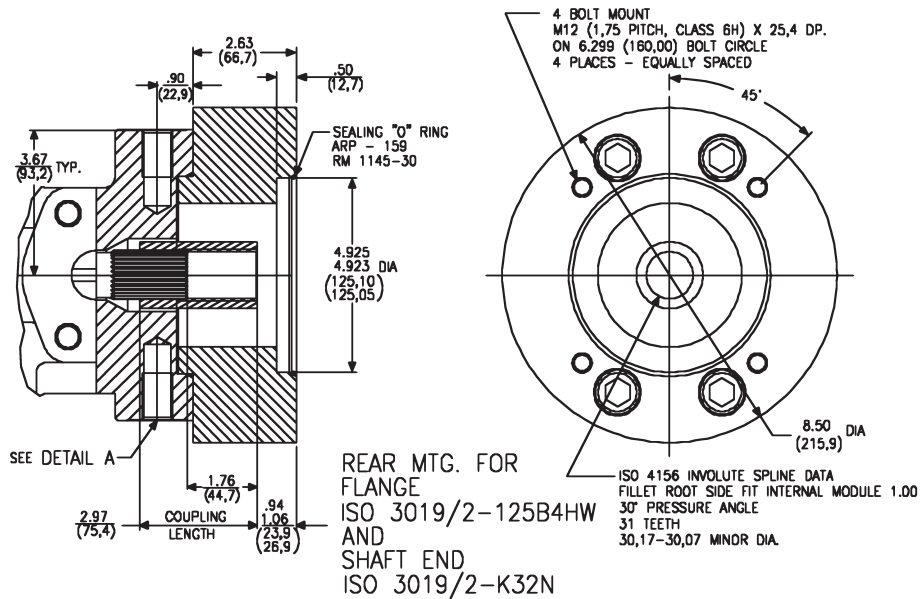
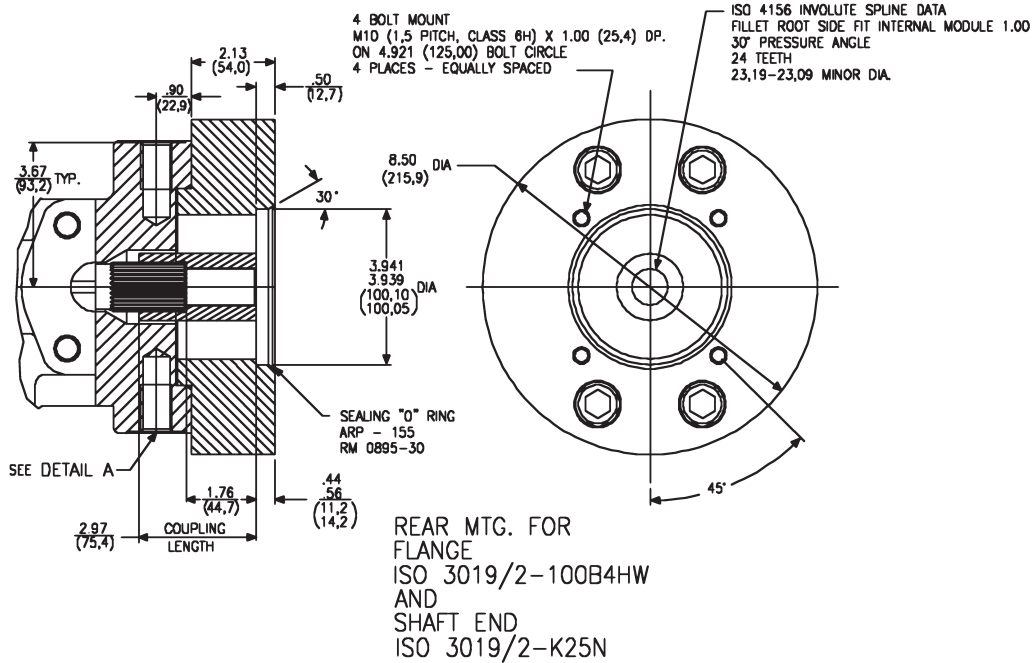

**ISO REAR AUX. MTG. ADAPTORS FOR ALL PREMIER SERIES
 ISO**

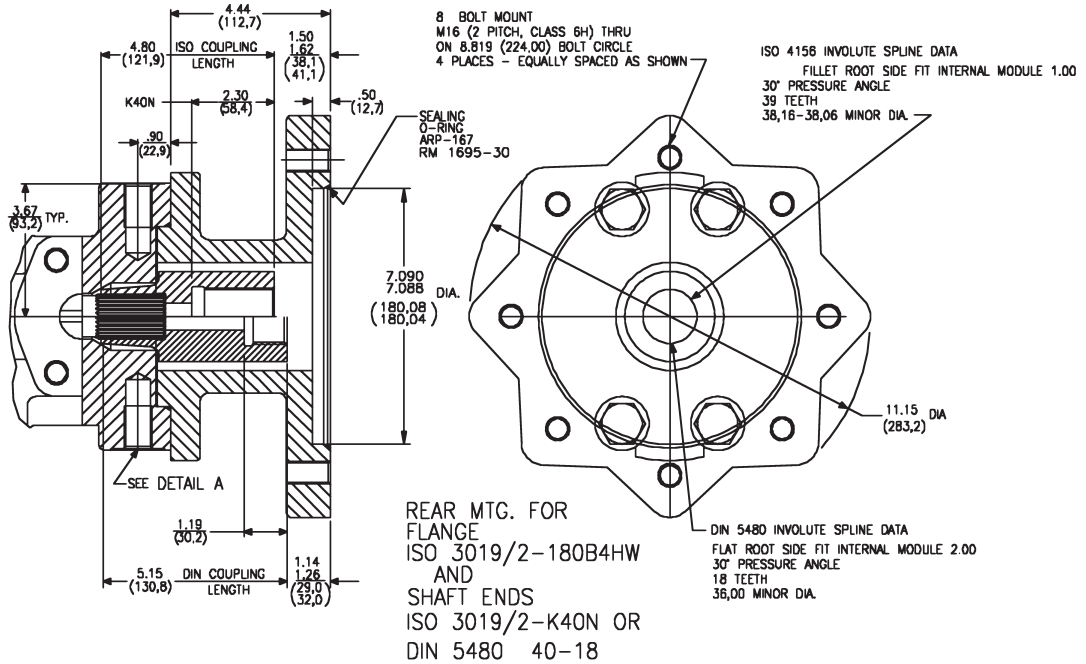
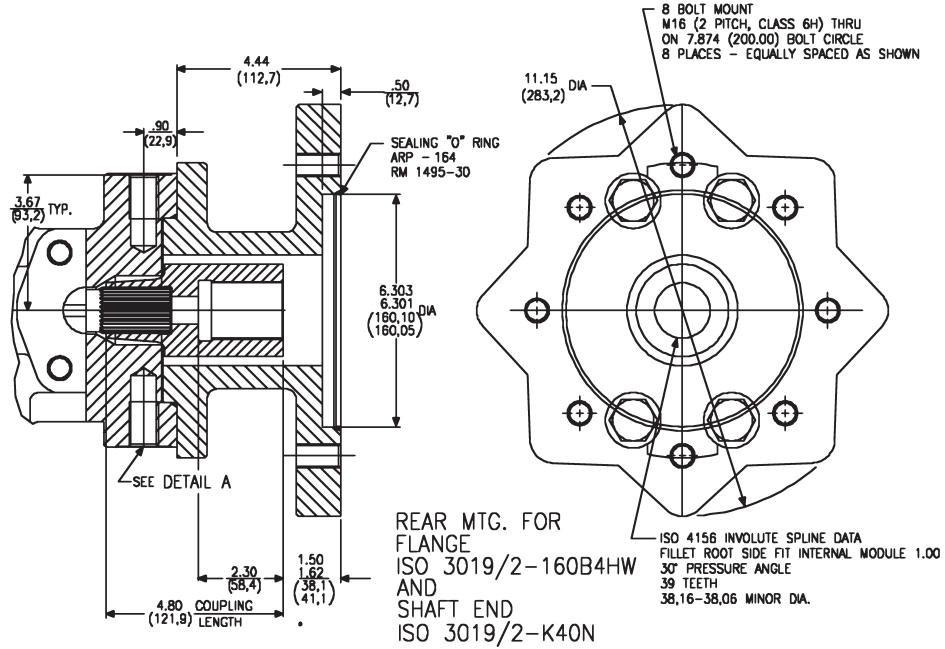

FOR P09, P140, P12, P200, P16 & P260 ONLY

ISO

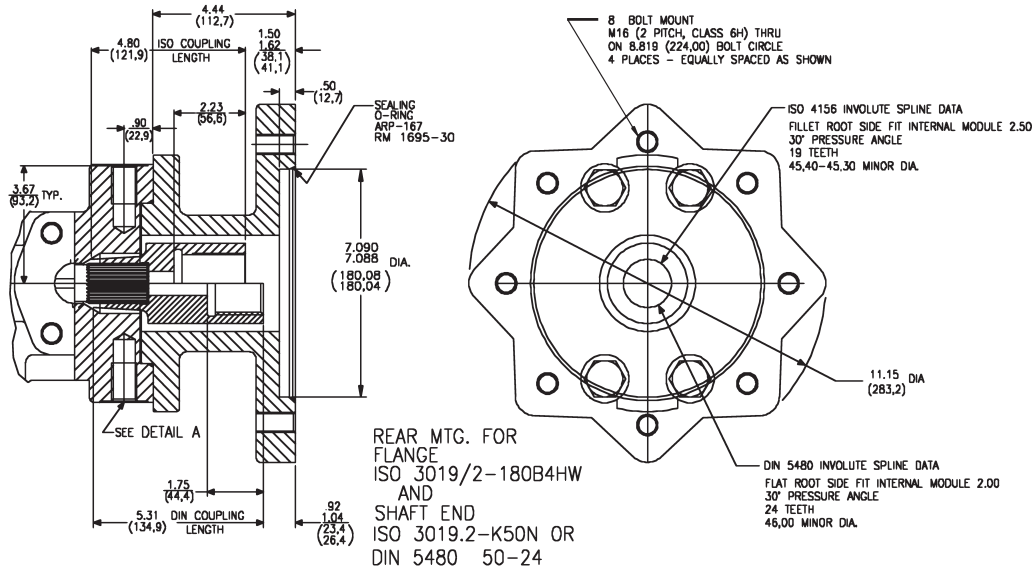

FOR P12, P200, P16 & P260 ONLY

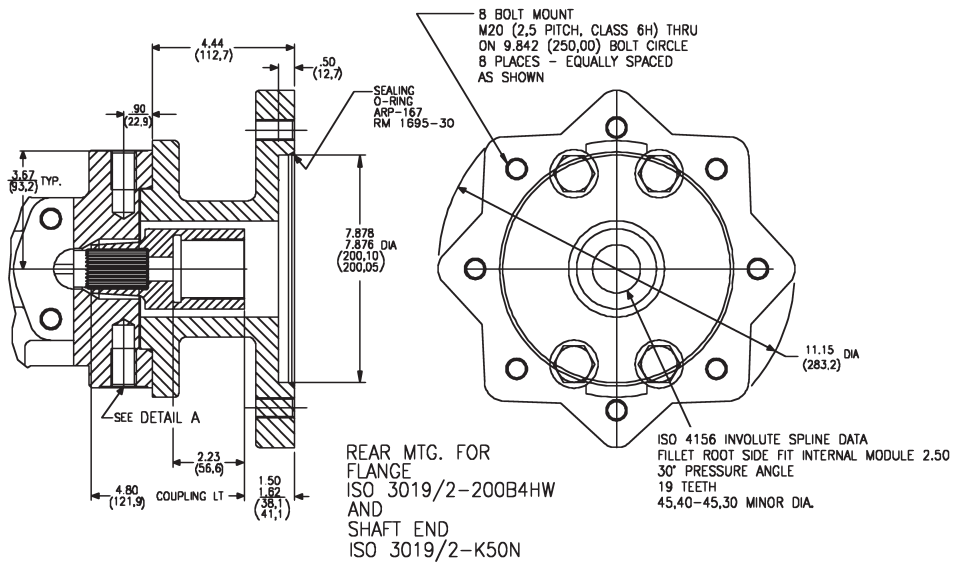

FOR P12, P200, P16 & P260 ONLY

ISO

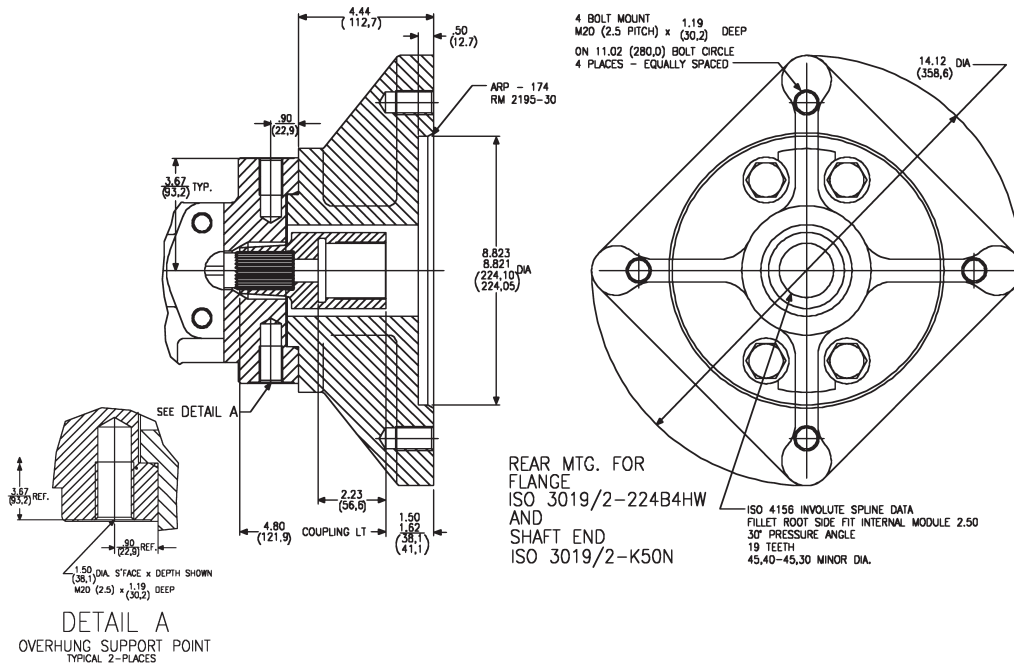

FOR P16 & P260 ONLY

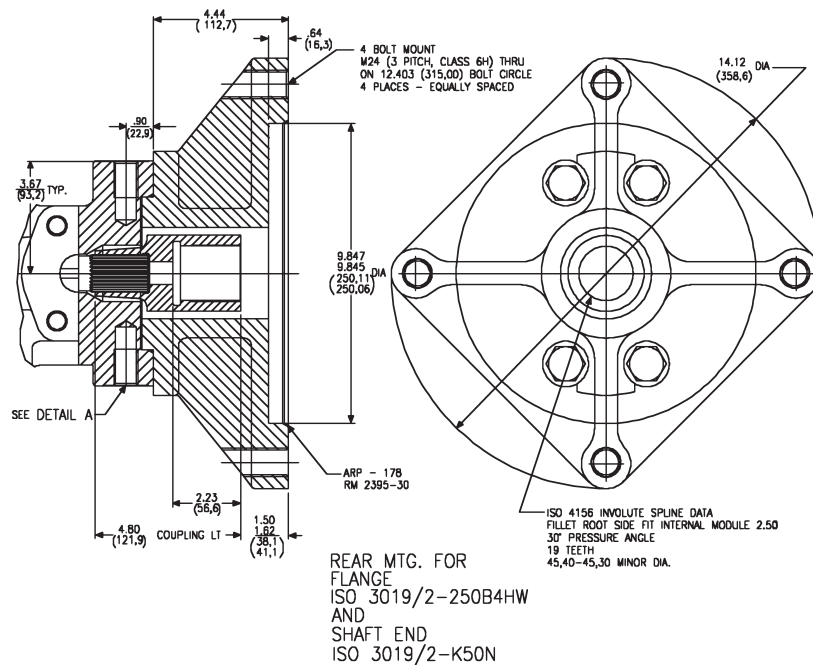

MAXIMUM PERMISSABLE BENDING MOMENT AT MOUNTING FLANGE

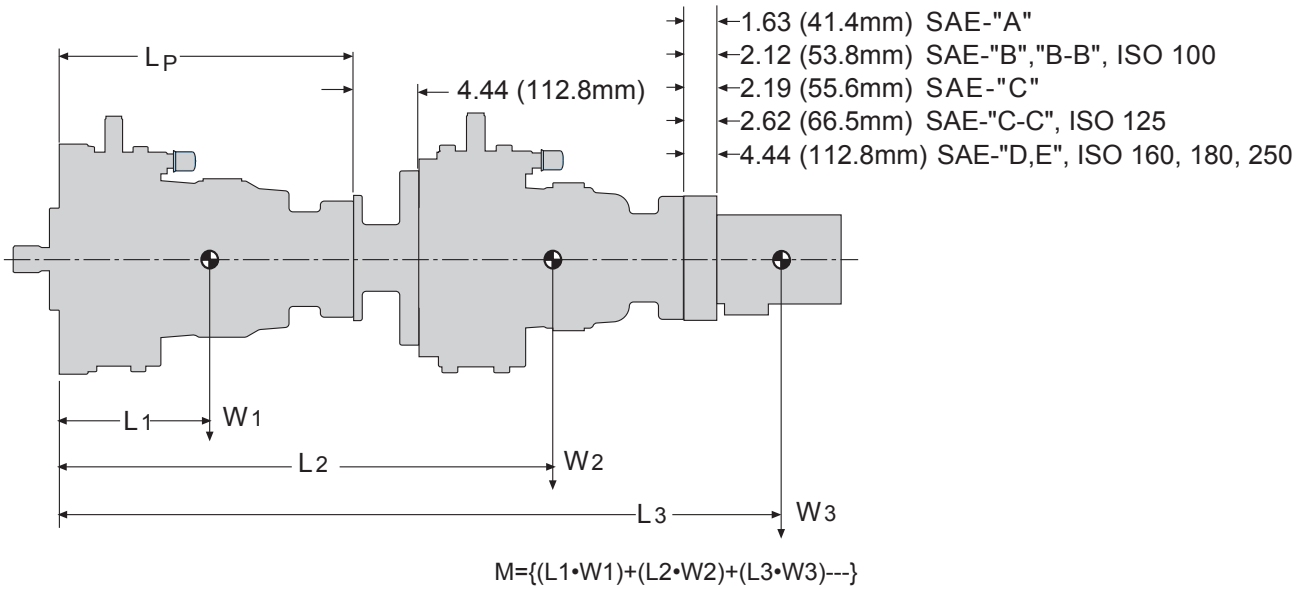

SERIES	P16	P12	P09	P07	P05
MAXIMUM MOMENT (lb.in.)	14400	10100	8300	6300	5000
WEIGHT - W (pounds)	325	300	220	177	156
DISTANCE - L1 (inches to C/G)	10.4	8.6	8.5	8.0	7.0
DISTANCE - Lp (inches)	18.8	17.2	15.9	14.7	13.4

SERIES	P260	P200	P140	P110	P080
MAXIMUM MOMENT (Nm)	1627	1141	938	712	565
WEIGHT - W (Newtons)	1446	1335	981	798	696
DISTANCE - L1 (mm to C/G)	264	218	216	203	178
DISTANCE - Lp (mm)	478	437	404	373	340

VALUES EXCEEDING MAXIMUM MOMENT MUST HAVE ADDITIONAL SUPPORT ON MOUNTED PUMP(S)

Rear drives ordering code options(P05-02R1C-C10-00-M2)

Mounting coupling	None / plugged	SAE mounting & coupling								ISO & DIN mounting & coupling									
		A	A	B	B	C	C	D	E	100B4	125B4	160B4	180B4	180B4	180B4	180B4	200B4	224B4	250B4
		A	A	B	B	C	C	D/E	DE	K25N	K32N	K40N	K40N	K50N	DIN40-18	DIN50-24	K50N	K50N	K50N
P05/P080	0 / M	A	G	B	Q	C	N	D	-	Z	Y	X	T	U	-	-	-	-	-
P07/P110	0 / M	A	G	B	Q	C	N	D	-	Z	Y	X	T	U	-	-	-	-	-
P09/P140	0 / M	A	G	B	Q	C	N	D	-	Z	Y	X	T	U	-	-	-	-	-
P12/P200	0 / M	A	G	B	Q	C	N	D	E	Z	Y	X	T	U	-	-	W	R	-
P16/P260	0 / M	A	G	B	Q	C	N	D	E	Z	Y	X	T	U	L	S	W	R	V
Dim. S	.88	1.63	2.13	2.19	2.62	4.44	2.13	2.63	4.44										
Dim. S	22,4	41,4	54,0	55,6	66,6	112,7	54,0	66,8	112,7										

NOTE: Items in **bold** are SAE version and inches, *italic* dimensions are in millimeters. For more detailed information refer to the individual pump installation drawings. These are available on CD. Contact your nearest sales representative or distributor.

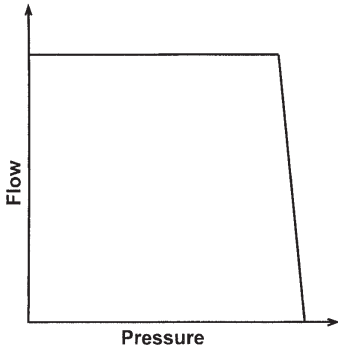
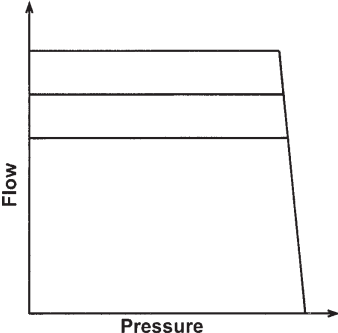
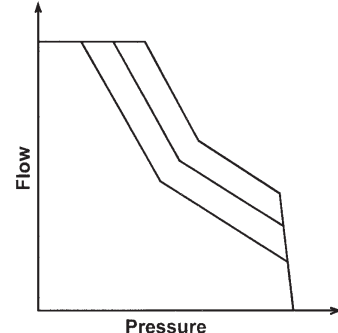

CODE	DESCRIPTION	HYDRAULIC CIRCUIT
C	PRESSURE COMPENSATOR	
L	LOAD SENSING CONTROL	
J & K	TORQUE LIMITER WITH PRESSURE COMPENSATOR	

TYPICAL PERFORMANCE	DESCRIPTION OF OPERATION																																																																						
<p>Minimum compensating pressure 250 PSI, 17,2 bar, pilot flow 115 in³/min. (1.9 L/min).</p> 	<p>When the pump operating pressure is below the compensator setting, a spring plus a piston pushes the stroking piston and the hanger toward full stroke. The stroking cylinder is connected to the case drain via the compensator spool. When the pump operating pressure reaches the compensator pressure setting, the pilot valve opens and a pressure drop is created over the orifice, causing the compensator spool to move against the spring force, directing pump discharge pressure to the stroking cylinder. The pump will destroke to maintain set pressure.</p> <p>When the pump operating pressure decreases below the compensator setting, the pilot valve will close and the compensator spool will move under spring force to its offset position, connecting the stroking cylinder to case. The spring plus the piston will move the stroking piston toward full displacement.</p> <table border="1" data-bbox="656 548 1360 716"> <thead> <tr> <th colspan="3">RESPONSE TIMES</th> </tr> <tr> <th></th> <th>Off stroke time</th> <th>on stroke time</th> </tr> </thead> <tbody> <tr> <td>P05/P80</td> <td>0.06</td> <td>0.11</td> </tr> <tr> <td>P07/P110</td> <td>0.07</td> <td>0.13</td> </tr> <tr> <td>P09/P140</td> <td>0.06</td> <td>0.11</td> </tr> <tr> <td>P12/P200*</td> <td>0.09</td> <td>0.15</td> </tr> <tr> <td>P16/P260</td> <td>0.10</td> <td>0.15</td> </tr> </tbody> </table>	RESPONSE TIMES				Off stroke time	on stroke time	P05/P80	0.06	0.11	P07/P110	0.07	0.13	P09/P140	0.06	0.11	P12/P200*	0.09	0.15	P16/P260	0.10	0.15																																																	
RESPONSE TIMES																																																																							
	Off stroke time	on stroke time																																																																					
P05/P80	0.06	0.11																																																																					
P07/P110	0.07	0.13																																																																					
P09/P140	0.06	0.11																																																																					
P12/P200*	0.09	0.15																																																																					
P16/P260	0.10	0.15																																																																					
	<p>The "L" compensator utilizes a modulating valve to isolate the load from compensator pilot flow. The load sensing port detects the load pressure and establishes the pressure on the vent port of the compensator at 50 psi, 3,4 bar above the load pressure. By adjusting the differential pressure across the compensator spool, the compensator establishes pump outlet pressure at 200 to 350 psi, 13,8 to 24,1 bar above the load pressure.</p> <p>The customer valve, by metering pump flow at a fixed pressure drop, becomes a flow control. The pump supplies only the required flow, at 200 to 350 psi, 13,8 to 24,1 bar above the load pressure.</p>																																																																						
	<p>The torque limiter is mounted on the control piston cap, full stroke side. One side of the spool is connected to the vent port of the compensator, the other to case. As system pressure increases, force on the spool overcomes the spring force shifting the spool to allow the flow to bleed off to case. This maintains the pressure and spring forces on the compensator spool. Once the system pressure overcomes the pressure plus spring force the compensator spool shifts and the pump begins to reduce displacement.</p> <p>Once the displacement is reduced, a higher pressure is required to overcome the compensator spring load at this new position. Thereby, pressure and pump stroke are inversely related.</p> <p>The slope of the pressure/stroke curve is determined by the spring rate. At low pressure a single spring is in contact with the spool. As pressure increases, a second spring joins the first to increase the rate of change of pressure vs. stroke. To cover a range of torques, two versions are offered, "J" for low torque values and "K" for high. Maximum pressure limits are controlled by the compensator settings.</p> <table border="1" data-bbox="651 1623 1367 1854"> <thead> <tr> <th rowspan="3">Model</th> <th colspan="8">Torque values for Torque Limiter and Torque Limiter Override controls</th> </tr> <tr> <th colspan="4">J or V</th> <th colspan="4">K or W</th> </tr> <tr> <th>Min. lb.-in.</th> <th>Nm</th> <th>Max. lb.-in.</th> <th>Nm</th> <th>Min. lb.-in.</th> <th>Nm</th> <th>Max. lb.-in.</th> <th>Nm</th> </tr> </thead> <tbody> <tr> <td>P05/080</td> <td>800</td> <td>90</td> <td>1500</td> <td>170</td> <td>1500</td> <td>170</td> <td>3500</td> <td>396</td> </tr> <tr> <td>P07/110</td> <td>1100</td> <td>124</td> <td>1850</td> <td>209</td> <td>1850</td> <td>209</td> <td>5300</td> <td>599</td> </tr> <tr> <td>P09/140</td> <td>1400</td> <td>158</td> <td>2200</td> <td>249</td> <td>2200</td> <td>249</td> <td>6000</td> <td>678</td> </tr> <tr> <td>P12/200</td> <td>1850</td> <td>209</td> <td>3400</td> <td>384</td> <td>3400</td> <td>384</td> <td>8000</td> <td>905</td> </tr> <tr> <td>P16/260</td> <td>2500</td> <td>283</td> <td>6000</td> <td>678</td> <td>6000</td> <td>678</td> <td>10000</td> <td>1129</td> </tr> </tbody> </table>	Model	Torque values for Torque Limiter and Torque Limiter Override controls								J or V				K or W				Min. lb.-in.	Nm	Max. lb.-in.	Nm	Min. lb.-in.	Nm	Max. lb.-in.	Nm	P05/080	800	90	1500	170	1500	170	3500	396	P07/110	1100	124	1850	209	1850	209	5300	599	P09/140	1400	158	2200	249	2200	249	6000	678	P12/200	1850	209	3400	384	3400	384	8000	905	P16/260	2500	283	6000	678	6000	678	10000	1129
Model	Torque values for Torque Limiter and Torque Limiter Override controls																																																																						
	J or V				K or W																																																																		
	Min. lb.-in.	Nm	Max. lb.-in.	Nm	Min. lb.-in.	Nm	Max. lb.-in.	Nm																																																															
P05/080	800	90	1500	170	1500	170	3500	396																																																															
P07/110	1100	124	1850	209	1850	209	5300	599																																																															
P09/140	1400	158	2200	249	2200	249	6000	678																																																															
P12/200	1850	209	3400	384	3400	384	8000	905																																																															
P16/260	2500	283	6000	678	6000	678	10000	1129																																																															

CODE	DESCRIPTION	HYDRAULIC CIRCUIT
V & W	TORQUE LIMITER WITH LOAD SENSING PRESSURE COMPENSATOR	
R	MANUAL ROTARY SERVO	
H	HYDRAULIC STROKER	

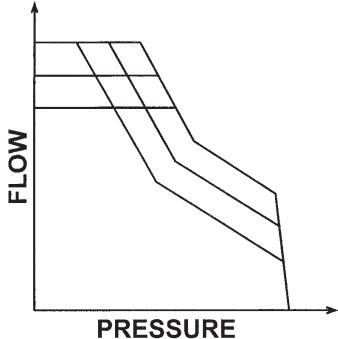
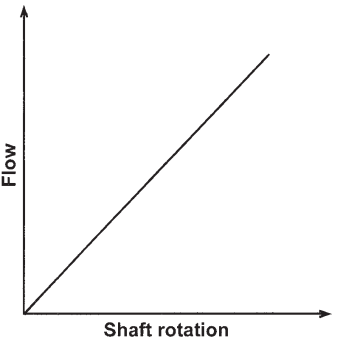
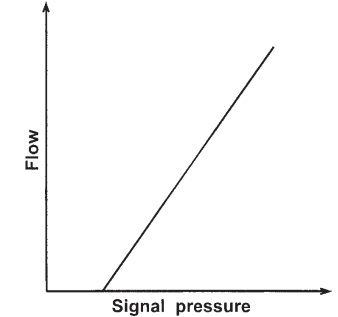
TYPICAL PERFORMANCE	DESCRIPTION OF OPERATION																																																																							
	<p>The V and W control offers the ability to control the torque and still operate as load sensing. The control operates as a load sense up to the point where pressure and flow cause torque to exceed the torque limiter setting. At this point the torque limiter destroys the pump to the given setting. A modulating valve on the vent line isolates the load from compensator pilot flow; therefore protecting any sensitive valves that may be in the system.</p> <p>The V control is for low torque, and the W control is for high torque. Remote control of the pressure compensator of the torque limiter is also possible. The maximum pressure limit is controlled by the compensator setting.</p> <table border="1" data-bbox="646 575 1349 804"> <thead> <tr> <th colspan="9">Torque values for Torque Limiter and Torque Limiter Override controls</th> </tr> <tr> <th rowspan="2">Model</th> <th colspan="4">J or V</th> <th colspan="4">K or W</th> </tr> <tr> <th>Min. lb.-in.</th> <th>Max. Nm</th> <th>Min. lb.-in.</th> <th>Max. Nm</th> <th>Min. lb.-in.</th> <th>Max. Nm</th> <th>Min. lb.-in.</th> <th>Max. Nm</th> </tr> </thead> <tbody> <tr> <td>P05/080</td> <td>800</td> <td>90</td> <td>1500</td> <td>170</td> <td>1500</td> <td>170</td> <td>3500</td> <td>396</td> </tr> <tr> <td>P07/110</td> <td>1100</td> <td>124</td> <td>1850</td> <td>209</td> <td>1850</td> <td>209</td> <td>5300</td> <td>599</td> </tr> <tr> <td>P09/140</td> <td>1400</td> <td>158</td> <td>2200</td> <td>249</td> <td>2200</td> <td>249</td> <td>6000</td> <td>678</td> </tr> <tr> <td>P12/200</td> <td>1850</td> <td>209</td> <td>3400</td> <td>384</td> <td>3400</td> <td>384</td> <td>8000</td> <td>905</td> </tr> <tr> <td>P16/260</td> <td>2500</td> <td>283</td> <td>6000</td> <td>678</td> <td>6000</td> <td>678</td> <td>10000</td> <td>1129</td> </tr> </tbody> </table>	Torque values for Torque Limiter and Torque Limiter Override controls									Model	J or V				K or W				Min. lb.-in.	Max. Nm	Min. lb.-in.	Max. Nm	Min. lb.-in.	Max. Nm	Min. lb.-in.	Max. Nm	P05/080	800	90	1500	170	1500	170	3500	396	P07/110	1100	124	1850	209	1850	209	5300	599	P09/140	1400	158	2200	249	2200	249	6000	678	P12/200	1850	209	3400	384	3400	384	8000	905	P16/260	2500	283	6000	678	6000	678	10000	1129
Torque values for Torque Limiter and Torque Limiter Override controls																																																																								
Model	J or V				K or W																																																																			
	Min. lb.-in.	Max. Nm	Min. lb.-in.	Max. Nm	Min. lb.-in.	Max. Nm	Min. lb.-in.	Max. Nm																																																																
P05/080	800	90	1500	170	1500	170	3500	396																																																																
P07/110	1100	124	1850	209	1850	209	5300	599																																																																
P09/140	1400	158	2200	249	2200	249	6000	678																																																																
P12/200	1850	209	3400	384	3400	384	8000	905																																																																
P16/260	2500	283	6000	678	6000	678	10000	1129																																																																
<p>Maximum servo pressure 1500 psi, 103 bar</p> 	<p>The manual rotary servo control is located on the control piston cap, minimum stroke side. A shaft, when rotated, causes linear motion on a spool. The spool contains a passage which is opened or blocked by a sleeve. This passage meters pilot flow on one end of a four-way valve. The sleeve is connected by a linkage to the control piston. The four-way valve connects servo and tank to the control piston, causing motion in the direction to follow the motion of the spool.</p> <p>Backlash is minimized by spring loading on the linkages. Stroke time is affected by servo pressure, system pressure, and servo flow. Maximum servo pressure is 1500 psi, 103 bar.</p> <table border="1" data-bbox="651 1129 1344 1220"> <thead> <tr> <th colspan="5">Servo shaft rotation, zero to full stroke</th> </tr> <tr> <th>P05/080</th> <th>P07/110</th> <th>P09/140</th> <th>P12/200</th> <th>P16/260</th> </tr> </thead> <tbody> <tr> <td>47-52°</td> <td>47-52°</td> <td>52-57°</td> <td>60-65°</td> <td>65-70°</td> </tr> </tbody> </table>	Servo shaft rotation, zero to full stroke					P05/080	P07/110	P09/140	P12/200	P16/260	47-52°	47-52°	52-57°	60-65°	65-70°																																																								
Servo shaft rotation, zero to full stroke																																																																								
P05/080	P07/110	P09/140	P12/200	P16/260																																																																				
47-52°	47-52°	52-57°	60-65°	65-70°																																																																				
	<p>The hydraulic stroker control is located on the control piston cap, minimum stroke side. The hydraulic stroker is obtained by replacing the rotary servo shaft and cam mechanism of the rotary servo configuration with a spring loaded hydraulic piston coupled to the spool. The piston is spring biased to initially stroke the pump to zero displacement. Pilot pressure applied to the piston causes the spool to move in proportion to pressure, thereby causing the pump to go on stroke in proportion to pilot pressure. Typical hysteresis is 7%.</p> <p>Maximum pilot pressure in the control port is 1000 psi, 70 bar. Maximum servo pressure is 1500 psi, 103 bar.</p> <table border="1" data-bbox="651 1654 1344 1835"> <thead> <tr> <th colspan="6">Hydraulic stroker signal pressure vs stroke</th> </tr> <tr> <th></th> <th>P05/080</th> <th>P07/110</th> <th>P09/140</th> <th>P12/200</th> <th>P16/260</th> </tr> </thead> <tbody> <tr> <td>zero stroke psi</td> <td>50</td> <td>50</td> <td>50</td> <td>50</td> <td>50</td> </tr> <tr> <td><i>zero stroke bar</i></td> <td><i>3,4</i></td> <td><i>3,4</i></td> <td><i>3,4</i></td> <td><i>3,4</i></td> <td><i>3,4</i></td> </tr> <tr> <td>full stroke psi</td> <td>225</td> <td>232</td> <td>245</td> <td>272</td> <td>283</td> </tr> <tr> <td><i>full stroke bar</i></td> <td><i>15,4</i></td> <td><i>16</i></td> <td><i>16,9</i></td> <td><i>18,8</i></td> <td><i>19,5</i></td> </tr> </tbody> </table>	Hydraulic stroker signal pressure vs stroke							P05/080	P07/110	P09/140	P12/200	P16/260	zero stroke psi	50	50	50	50	50	<i>zero stroke bar</i>	<i>3,4</i>	<i>3,4</i>	<i>3,4</i>	<i>3,4</i>	<i>3,4</i>	full stroke psi	225	232	245	272	283	<i>full stroke bar</i>	<i>15,4</i>	<i>16</i>	<i>16,9</i>	<i>18,8</i>	<i>19,5</i>																																			
Hydraulic stroker signal pressure vs stroke																																																																								
	P05/080	P07/110	P09/140	P12/200	P16/260																																																																			
zero stroke psi	50	50	50	50	50																																																																			
<i>zero stroke bar</i>	<i>3,4</i>	<i>3,4</i>	<i>3,4</i>	<i>3,4</i>	<i>3,4</i>																																																																			
full stroke psi	225	232	245	272	283																																																																			
<i>full stroke bar</i>	<i>15,4</i>	<i>16</i>	<i>16,9</i>	<i>18,8</i>	<i>19,5</i>																																																																			

CODE	DESCRIPTION	HYDRAULIC CIRCUIT
E	ELECTRIC STROKER	

**PRIMARY CONTROL OPTIONS
MAXIMUM VOLUME SCREW**
code 1

The standard maximum volume stop is an adjustment screw. To reduce volume, remove the plug on the end of the cover, loosen the cover, and turn the adjusting screw clockwise.

**HANDWHEEL MAXIMUM
VOLUME STOP**
code 2

An optional handwheel maximum volume stop is available on the pressure compensator, load sensing and torque limiter controls. To reduce volume, loosen the locknut below the handwheel and turn the handwheel clockwise.

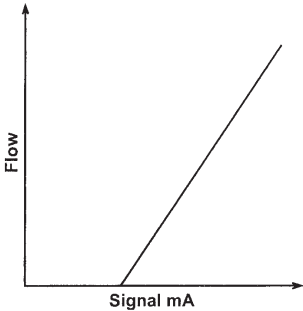
TYPICAL PERFORMANCE	DESCRIPTION OF OPERATION																																				
	<p>The electric stoker consists of the hydraulic stoker with an electrically modulated pressure control valve mounted. Pump stroke may be controlled with an electrical signal which controls the pressure to the control port of the hydraulic stoker.</p> <p>Servo pressure, not to exceed 1500 psi, (103 bar) is supplied to the inlet port on the electrically modulated pressure control valve. The Jupiter Driver card, S20-14078 or the Micro Proportional Driver plug, S20-14116 may be used to control the electric stoker. A 12 Volt coil is also available.</p> <p>Typical hysteresis 5%.</p> <table border="1" data-bbox="678 606 1369 751"> <thead> <tr> <th colspan="6">Electrohydraulic stoker signal mA vs stroke</th> </tr> <tr> <th></th> <th>P05/080</th> <th>P07/110</th> <th>P09/140</th> <th>P12/200</th> <th>P16/260</th> </tr> </thead> <tbody> <tr> <td>zero stroke mA, 24 vdc</td> <td>175</td> <td>175</td> <td>175</td> <td>175</td> <td>175</td> </tr> <tr> <td>zero stroke mA, 12 vdc</td> <td>350</td> <td>350</td> <td>350</td> <td>350</td> <td>350</td> </tr> <tr> <td>full stroke mA, 24 vdc</td> <td>273</td> <td>276</td> <td>283</td> <td>295</td> <td>300</td> </tr> <tr> <td>full stroke mA, 12 vdc</td> <td>546</td> <td>552</td> <td>566</td> <td>590</td> <td>600</td> </tr> </tbody> </table>	Electrohydraulic stoker signal mA vs stroke							P05/080	P07/110	P09/140	P12/200	P16/260	zero stroke mA, 24 vdc	175	175	175	175	175	zero stroke mA, 12 vdc	350	350	350	350	350	full stroke mA, 24 vdc	273	276	283	295	300	full stroke mA, 12 vdc	546	552	566	590	600
Electrohydraulic stoker signal mA vs stroke																																					
	P05/080	P07/110	P09/140	P12/200	P16/260																																
zero stroke mA, 24 vdc	175	175	175	175	175																																
zero stroke mA, 12 vdc	350	350	350	350	350																																
full stroke mA, 24 vdc	273	276	283	295	300																																
full stroke mA, 12 vdc	546	552	566	590	600																																

CODE	DESCRIPTION	HYDRAULIC CIRCUIT
<p>E1P H1P R1P</p>	<p>COMPENSATOR OVERRIDE</p>	
<p>E1J E1K H1J H1K R1J R1K</p>	<p>TORQUE LIMITER OVERRIDE, INCLUDING PRESSURE COMPENSATOR OVERRIDE</p>	

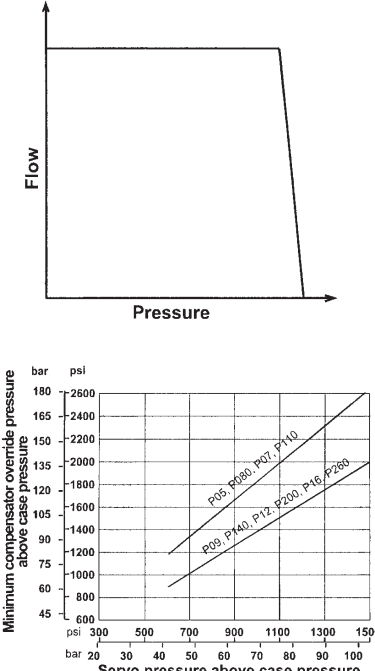
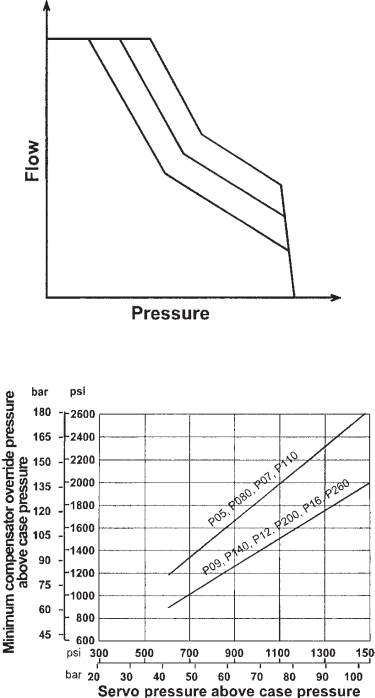
TYPICAL PERFORMANCE	DESCRIPTION OF OPERATION																																																															
	<p>The pressure compensator override is located in the control piston cap, full stroke side. It may be installed with any of the three position controls, (servo, hydraulic, or electrohydraulic stroker). When pressure exceeds compensator setting, the compensator override ports system pressure into the off-stroke side of the control cylinder and blocks that flow path to the servo, hydraulic or electrohydraulic stroker. When system pressure is below the compensator override setting, the primary control functions to control pump stroke. Compensator override pressure must be sufficient to overcome servo pressure applied to the opposite side of the control piston.</p> <table border="1" data-bbox="639 537 1390 718"> <thead> <tr> <th colspan="3">RESPONSE TIMES, sec. at 800 psi (55 bar) servo pressure</th> </tr> <tr> <th></th> <th>Off stroke time</th> <th>on stroke time</th> </tr> </thead> <tbody> <tr> <td>P05/P80</td> <td>0.06</td> <td>.20</td> </tr> <tr> <td>P07/P110</td> <td>0.07</td> <td>.20</td> </tr> <tr> <td>P09/P140</td> <td>0.06</td> <td>.25</td> </tr> <tr> <td>P12/P200</td> <td></td> <td></td> </tr> <tr> <td>P16/P260</td> <td>0.10</td> <td>.30</td> </tr> </tbody> </table>	RESPONSE TIMES, sec. at 800 psi (55 bar) servo pressure				Off stroke time	on stroke time	P05/P80	0.06	.20	P07/P110	0.07	.20	P09/P140	0.06	.25	P12/P200			P16/P260	0.10	.30																																										
RESPONSE TIMES, sec. at 800 psi (55 bar) servo pressure																																																																
	Off stroke time	on stroke time																																																														
P05/P80	0.06	.20																																																														
P07/P110	0.07	.20																																																														
P09/P140	0.06	.25																																																														
P12/P200																																																																
P16/P260	0.10	.30																																																														
	<p>The torque limiter override is located in the control piston cap, full stroke side. It may be installed with any of the three position controls, (servo, hydraulic or electrohydraulic stroker). As with the pressure compensator override, the torque limiter override directs oil into the cylinder to overcome the servo pressure signal on the opposite side, causing the control cylinder to reduce stroke when the torque limiter setting is reached.</p> <table border="1" data-bbox="639 1188 1390 1583"> <thead> <tr> <th colspan="7">Minimum torque limiter override settings as a function of servo pressure</th> </tr> <tr> <th>Servo pressure (psi)</th> <th>P05/080</th> <th>P07/110</th> <th>P09/140</th> <th>P12/200</th> <th>P16/260</th> <th>Minimum torque</th> </tr> </thead> <tbody> <tr> <td>700</td> <td></td> <td></td> <td>1800</td> <td>2500</td> <td>3100</td> <td>lb.-in</td> </tr> <tr> <td>800</td> <td>1400</td> <td>1800</td> <td></td> <td></td> <td></td> <td>lb.-in</td> </tr> <tr> <td>1500</td> <td>2700</td> <td>3500</td> <td>3400</td> <td>4800</td> <td>6200</td> <td>lb.-in</td> </tr> <tr> <th>Servo pressure (bar)</th> <th>P05/080</th> <th>P07/110</th> <th>P09/140</th> <th>P12/200</th> <th>P16/260</th> <th>Minimum torque</th> </tr> <tr> <td>48</td> <td></td> <td></td> <td>203</td> <td>283</td> <td>350</td> <td>Nm</td> </tr> <tr> <td>55</td> <td>158</td> <td>203</td> <td></td> <td></td> <td></td> <td>Nm</td> </tr> <tr> <td>103</td> <td>305</td> <td>396</td> <td>384</td> <td>542</td> <td>701</td> <td>Nm</td> </tr> </tbody> </table>	Minimum torque limiter override settings as a function of servo pressure							Servo pressure (psi)	P05/080	P07/110	P09/140	P12/200	P16/260	Minimum torque	700			1800	2500	3100	lb.-in	800	1400	1800				lb.-in	1500	2700	3500	3400	4800	6200	lb.-in	Servo pressure (bar)	P05/080	P07/110	P09/140	P12/200	P16/260	Minimum torque	48			203	283	350	Nm	55	158	203				Nm	103	305	396	384	542	701	Nm
Minimum torque limiter override settings as a function of servo pressure																																																																
Servo pressure (psi)	P05/080	P07/110	P09/140	P12/200	P16/260	Minimum torque																																																										
700			1800	2500	3100	lb.-in																																																										
800	1400	1800				lb.-in																																																										
1500	2700	3500	3400	4800	6200	lb.-in																																																										
Servo pressure (bar)	P05/080	P07/110	P09/140	P12/200	P16/260	Minimum torque																																																										
48			203	283	350	Nm																																																										
55	158	203				Nm																																																										
103	305	396	384	542	701	Nm																																																										

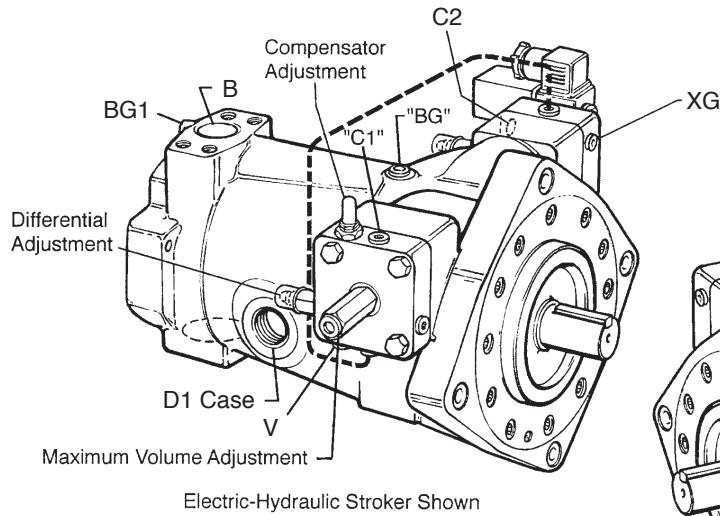

Electric-Hydraulic Stroker Shown

CCW ROTATION

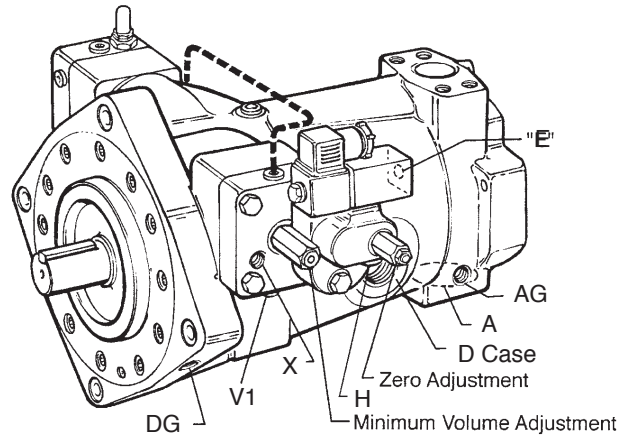

Electric-Hydraulic Stroker Shown

FLUID CONNECTIONS

DESCRIPTION

- PORT AINLET
- PORT BSYSTEM

- PORT C1OFF-STROKE CYL. GAGE
- PORT C2ON-STROKE CYL. GAGE
- PORT DCASE DRAIN
- PORT D1CASE DRAIN
- PORT DG.....DRAIN GAGE, AIR BLEED PORT
- PORT AG.....INLET GAGE
- PORT BG.....SYSTEM GAGE
- PORT BG1.....ALT. SYS. GAGE
- PORT EELECTROHYDRAULIC STROKER SERVO SUPPLY
- PORT HHYDRAULIC STROKER SIGNAL
- PORT LSLOAD SENSING LINE
- PORT VCOMPENSATOR, TORQUE LIMITER, LOAD SENSING VENT
- PORT VOVERRIDE COMP, OVERRIDE TORQUE LIMITER VENT
- PORT V1SERVO VENT
- PORT XSERVO SUPPLY
- PORT XG.....SERVO GAGE

Premier pumps		Model number sheet											
Example model code:		P	16	H	-02	R	1	*	-C	0	0	-C	0
		P											
Pump													
Displacement													
4.9 cu.in./rev.	05												
80.3 cc/rev.	080												
6.7 cu.in./rev.	07												
109.8 cc/rev.	110												
8.6 cu.in./rev.	09												
140.9 cc/rev.	140												
12.2 cu.in./rev.	12												
200.0 cc/rev.	200												
16.0 cu.in./rev.	16												
262.2 cc/rev.	260												
Style													
High speed (>1800 RPM)(P16, P260, P12, P200, P09 & P140 only)	H												
Low Speed (=/ $<$ 1800 rpm)(P16, P260, P12, P200, P09 & P140 only)	L												
High Speed Stand-By Option (>1800 rpm)(P16, P260, P12, P200, P09 & P140 only)	M												
Low Speed Stand-By Option (=/ $<$ 1800 rpm)(P16, P260, P12, P200, P09 & P140 only)	N												
P07, P110, P05 & P080	leave blank												
Shaft													
Keyed - SAE or ISO	2												
Splined - SAE or ISO	3												
Splined - SAE high torque (P16 only)	5												
Keyed - DIN (metric pumps only) (DIN 40mm for sizes 080 & 110, DIN 50mm for sizes 140 & 200)	6												
Splined - DIN (metric pumps only) (DIN 40mm for sizes 080 & 110, DIN 50mm for sizes 140 & 200)	7												
Keyed - DIN (DIN 60mm for size 200 only)	8												
Splined - DIN (DIN 60mm for size 200 only)	9												
Rotation													
Clockwise	R												
Counter-clockwise	L												
Seals													
Nitrile (Buna-N)	1												
EPR (pump will be unpainted unless otherwise specified)*	4												
Fluorocarbon (Viton)	5												
Design letter (assigned by manufacturer)													
Primary controls													
Compensator	-C												
Load sensing compensator (50 PSI pressure drop)	-L												
Load sensing compensator (200 PSI pressure drop)	-M												
Rotary servo	-R												
Hydraulic servo	-H												
Electro-hydraulic servo**	-E												
Low torque limiter	-J												
High torque limiter	-K												
Load sensing (L) + low torque limiter (J)	-V												
Load sensing (L) + high torque limiter (K)	-W												
Load sensing (M) + low torque limiter (J)	-Y												
Load sensing (M) + high torque limiter (K)	-Z												
Primary control options													
Max. volume screw without indicator	1												
Handwheel max. volume control without indicator (not available w/ R, H & E primary controls)	2												
Max. volume screw with LVDT**	4												
Max. volume screw with mechanical cam angle indicator	5												
Handwheel max. volume control with LVDT (not available w/ R, H & E primary controls)**	7												
Handwheel max. volume control with mechanical cam angle indicator (not available w/ R, H & E primary controls)	8												
Secondary controls													
None	0												
Compensator override (for E, H & R primary controls only)	P												
Low torque limiter override (for E, H & R primary controls only)	J												
High torque limiter override (for E, H & R primary controls only)	K												
External drive													
None	-0												
Rear blanking plate	-M												
SAE-A (SAE 82-2) with SAE-A (SAE 16-4) coupling	-A												
SAE-A (SAE 82-2) with SAE-B (SAE 22-4) coupling	-G												
SAE-B (SAE 101-2 & SAE 101-4) with SAE-B (SAE 22-4) coupling	-B												
SAE-B (SAE 101-2 & SAE 101-4) with SAE-BB (SAE 25-4) coupling	-Q												
SAE-C (SAE 127-2 & SAE 127-4) with SAE-C (SAE 32-4) coupling	-C												
SAE-C (SAE 127-2 & SAE 127-4) with SAE-CC (SAE 38-4) coupling	-N												
SAE-D (SAE 152-2 & SAE 152-4) with SAE-D & SAE-E (SAE 44-4) coupling	-D												
SAE-E (SAE 165-2 & SAE 165-4) with SAE-D & SAE-E (SAE 44-4) coupling (P12/200 and P16/260 only)	-E												
ISO 180 B4HW Flange, K40N coupling	-T												
ISO 180 B4HW Flange, K50N coupling	-U												
ISO 180 B4HW Flange, DIN 40-18 coupling (P16/260 only)	-L												
ISO 180 B4HW Flange, DIN 50-24 coupling (P16/260 only)	-S												
ISO 224 B4HW Flange, K50N coupling (P12/200 and P16/260 only)	-R												
ISO 250 B4HW Flange, K50N coupling (P16/260 only)	-V												
ISO 200 B4HW Flange, K50N coupling (P12/200 and P16/260 only)	-W												
ISO 160 B4HW Flange, K40N coupling	-X												
ISO 125 B4HW Flange, K32N coupling	-Y												
ISO 100 B4HW Flange, K25N coupling	-Z												
External mounting													
No external pump mounted	0												
External pump mounted (requires special modification "-M2")(must be separately specified)	1												
Special modification													
No paint*	-NP												
Painted black	-PB												
ATEX APPROVED PUMP	-EX												
Other special modification (examples: bronze caged barrel bearing for low viscosity fluids, mechanical shaft seal, hydrostatic cam, tandem pumps, etc.)*	-M2												
Allowable controls**													
C10, C20, C40, C50, C70, C80, E10, E40, E50, E1P, E4P, E5P, E1J, E4J, E5J, E1K, E4K, E5K, H10, H40, H50, H1P, H4P, H5P, H1J, H4J, H5J, H1K, H4K, H5K, J10, J20, J40, J50, J70, J80, K10, K20, K40, K50, K70, K80, L10, L20, L40, L50, L70, L80, M10, M20, M40, M50, M70, M80, R10, R40, R50, R1P, R4P, R5P, R1J, R4J, R5J, R1K, R4K, R5K, V10, V20, V40, V50, V70, V80, W10, W20, W40, W50, W70, W80, Y10, Y20, Y40, Y50, Y70, Y80, Z10, Z20, Z40, Z50, Z70, Z80													

* ATEX NOTES:
 THESE OPTIONS ARE NOT APPROVED FOR ATEX APPLICATIONS

** THE FOLLOWING CONTROL OPTIONS ARE NOT AVAILABLE FOR ATEX 2014/34/EU: Electro-Hydraulic Servo(E**), and use of LVDT position feedback (*4* or *7*)



Offer of Sale

The items described in this document and other documents and descriptions provided by Parker Hannifin Corporation, Hydraulics Group, and its authorized distributors ("Seller") are hereby offered for sale at prices to be established by Seller. This offer and its acceptance by any customer ("Buyer") shall be governed by all of the following Terms and Conditions. Buyer's order for any item described in its document, when communicated to Seller verbally, or in writing, shall constitute acceptance of this offer. All goods or work described will be referred to as "Products".

1. Terms and Conditions. Seller's willingness to offer Products, or accept an order for Products, to or from Buyer is expressly conditioned on Buyer's assent to these Terms and Conditions and to the terms and conditions found on-line at www.parker.com/saleterms/. Seller objects to any contrary or additional term or condition of Buyer's order or any other document issued by Buyer.

2. Price Adjustments; Payments. Prices stated on the reverse side or preceding pages of this document are valid for 30 days. After 30 days, Seller may change prices to reflect any increase in its costs resulting from state, federal or local legislation, price increases from its suppliers, or any change in the rate, charge, or classification of any carrier. The prices stated on the reverse or preceding pages of this document do not include any sales, use, or other taxes unless so stated specifically. Unless otherwise specified by Seller, all prices are F.O.B. Seller's facility, and payment is due 30 days from the date of invoice. After 30 days, Buyer shall pay interest on any unpaid invoices at the rate of 1.5% per month or the maximum allowable rate under applicable law.

3. Delivery Dates; Title and Risk; Shipment. All delivery dates are approximate and Seller shall not be responsible for any damages resulting from any delay. Regardless of the manner of shipment, title to any products and risk of loss or damage shall pass to Buyer upon tender to the carrier at Seller's facility (i.e., when it's on the truck, it's yours). Unless otherwise stated, Seller may exercise its judgment in choosing the carrier and means of delivery. No deferment of shipment at Buyers' request beyond the respective dates indicated will be made except on terms that will indemnify, defend and hold Seller harmless against all loss and additional expense. Buyer shall be responsible for any additional shipping charges incurred by Seller due to Buyer's changes in shipping, product specifications or in accordance with Section 13, herein.

4. Warranty. Seller warrants that the Products sold hereunder shall be free from defects in material or workmanship for a period of eighteen months from the date of delivery to Buyer. The prices charged for Seller's products are based upon the exclusive limited warranty stated above, and upon the following disclaimer: **DISCLAIMER OF WARRANTY: THIS WARRANTY COMPRISES THE SOLE AND ENTIRE WARRANTY PERTAINING TO PRODUCTS PROVIDED HEREUNDER. SELLER DISCLAIMS ALL OTHER WARRANTIES, EXPRESS AND IMPLIED, INCLUDING MERCHANTABILITY AND FITNESS FOR A PARTICULAR PURPOSE.**

5. Claims; Commencement of Actions. Buyer shall promptly inspect all Products upon delivery. No claims for shortages will be allowed unless reported to the Seller within 10 days of delivery. No other claims against Seller will be allowed unless asserted in writing within 60 days after delivery or, in the case of an alleged breach of warranty, within 30 days after the date within the warranty period on which the defect is or should have been discovered by Buyer. Any action based upon breach of this agreement or upon any other claim arising out of this sale (other than an action by Seller for any amount due to Seller from Buyer) must be commenced within thirteen months from the date of tender of delivery by Seller or, for a cause of action based upon an alleged breach of warranty, within thirteen months from the date within the warranty period on which the defect is or should have been discovered by Buyer.

6. LIMITATION OF LIABILITY. UPON NOTIFICATION, SELLER WILL, AT ITS OPTION, REPAIR OR REPLACE A DEFECTIVE PRODUCT, OR REFUND THE PURCHASE PRICE. IN NO EVENT SHALL SELLER BE LIABLE TO BUYER FOR ANY SPECIAL, INDIRECT, INCIDENTAL OR CONSEQUENTIAL DAMAGES ARISING OUT OF, OR AS THE RESULT OF, THE SALE, DELIVERY, NON-DELIVERY, SERVICING, USE OR LOSS OF USE OF THE PRODUCTS OR ANY PART THEREOF, OR FOR ANY CHARGES OR EXPENSES OF ANY NATURE INCURRED WITHOUT SELLER'S WRITTEN CONSENT, EVEN IF SELLER HAS BEEN NEGLIGENT, WHETHER IN CONTRACT, TORT OR OTHER LEGAL THEORY. IN NO EVENT SHALL SELLER'S LIABILITY UNDER ANY CLAIM MADE BY BUYER EXCEED THE PURCHASE PRICE OF THE PRODUCTS.

7. Contingencies. Seller shall not be liable for any default or delay in performance if caused by circumstances beyond the reasonable control of Seller.

8. User Responsibility. The user, through its own analysis and testing, is solely responsible for making the final selection of the system and Product and assuring that all performance, endurance, maintenance, safety and warning requirements of the application are met. The user must analyze all aspects of the application and follow applicable industry standards and Product information. If Seller provides Product or system options, the user is responsible for determining that such data and specifications are suitable and sufficient for all applications and reasonably foreseeable uses of the Products or systems.

9. Loss to Buyer's Property. Any designs, tools, patterns, materials, drawings, confidential information or equipment furnished by Buyer or any other items which become Buyer's property, may be considered obsolete and may be destroyed by Seller after two consecutive years have elapsed without Buyer placing an order for the items which are manufactured using such property. Seller shall not be responsible for any loss or damage to such property while it is in Seller's possession or control.

10. Special Tooling. A tooling charge may be imposed for any special tooling, including without limitation, dies, fixtures, molds and patterns, acquired to manufacture Products. Such special tooling shall be and remain Seller's property notwithstanding payment of any charges by Buyer. In no event will Buyer acquire any interest in apparatus belonging to Seller which is utilized in the manufacture of the Products, even if such apparatus has been specially converted or adapted for such manufacture and notwithstanding any charges paid by Buyer. Unless otherwise agreed, Seller shall have the right to alter, discard or otherwise dispose of any special tooling or other property in its sole discretion at any time.

11. Buyer's Obligation; Rights of Seller. To secure payment of all sums due or otherwise, Seller shall retain a security interest in the goods delivered and this agreement shall be deemed a Security Agreement under the Uniform Commercial Code. Buyer authorizes Seller as its attorney to execute and file on Buyer's behalf all documents Seller deems necessary to perfect its security interest. Seller shall have a security interest in, and lien upon, any property of Buyer in Seller's possession as security for the payment of any amounts owed to Seller by Buyer.

12. Improper Use and Indemnity. Buyer shall indemnify, defend, and hold Seller harmless from any claim, liability, damages, lawsuits, and costs (including attorney fees), whether for personal injury, property damage, patent, trademark or copyright infringement or any other claim, brought by or incurred by Buyer, Buyer's employees, or any other person, arising out of: (a) improper selection, improper application or other misuse of Products purchased by Buyer from Seller; (b) any act or omission, negligent or otherwise, of Buyer; (c) Seller's use of patterns, plans, drawings, or specifications furnished by Buyer to manufacture Product; or (d) Buyer's failure to comply with these terms and conditions. Seller shall not indemnify Buyer under any circumstance except as otherwise provided.

13. Cancellations and Changes. Orders shall not be subject to cancellation or change by Buyer for any reason, except with Seller's written consent and upon terms that will indemnify, defend and hold Seller harmless against all direct, incidental and consequential loss or damage. Seller may change product features, specifications, designs and availability with notice to Buyer.

14. Limitation on Assignment. Buyer may not assign its rights or obligations under this agreement without the prior written consent of Seller.

15. Entire Agreement. This agreement contains the entire agreement between the Buyer and Seller and constitutes the final, complete and exclusive expression of the terms of the agreement. All prior or contemporaneous written or oral agreements or negotiations with respect to the subject matter are herein merged.

16. Waiver and Severability. Failure to enforce any provision of this agreement will not waive that provision nor will any such failure prejudice Seller's right to enforce that provision in the future. Invalidation of any provision of this agreement by legislation or other rule of law shall not invalidate any other provision herein. The remaining provisions of this agreement will remain in full force and effect.

17. Termination. This agreement may be terminated by Seller for any reason and at any time by giving Buyer thirty (30) days written notice of termination. In addition, Seller may by written notice immediately terminate this agreement for the following: (a) Buyer commits a breach of any provision of this agreement (b) the appointment of a trustee, receiver or custodian for all or any part of Buyer's property (c) the filing of a petition for relief in bankruptcy of the other Party on its own behalf, or by a third party (d) an assignment for the benefit of creditors, or (e) the dissolution or liquidation of the Buyer.

18. Governing Law. This agreement and the sale and delivery of all Products hereunder shall be deemed to have taken place in and shall be governed and construed in accordance with the laws of the State of Ohio, as applicable to contracts executed and wholly performed therein and without regard to conflicts of laws principles. Buyer irrevocably agrees and consents to the exclusive jurisdiction and venue of the courts of Cuyahoga County, Ohio with respect to any dispute, controversy or claim arising out of or relating to this agreement. Disputes between the parties shall not be settled by arbitration unless, after a dispute has arisen, both parties expressly agree in writing to arbitrate the dispute.

19. Indemnity for Infringement of Intellectual Property Rights. Seller shall have no liability for infringement of any patents, trademarks, copyrights, trade dress, trade secrets or similar rights except as provided in this Section. Seller will defend and indemnify Buyer against allegations of infringement of U.S. patents, U.S. trademarks, copyrights, trade dress and trade secrets ("Intellectual Property Rights"). Seller will defend at its expense and will pay the cost of any settlement or damages awarded in an action brought against Buyer based on an allegation that a Product sold pursuant to this Agreement infringes the Intellectual Property Rights of a third party. Seller's obligation to defend and indemnify Buyer is contingent on Buyer notifying Seller within ten (10) days after Buyer becomes aware of such allegations of infringement, and Seller having sole control over the defense of any allegations or actions including all negotiations for settlement or compromise. If a Product is subject to a claim that it infringes the Intellectual Property Rights of a third party, Seller may, at its sole expense and option, procure for Buyer the right to continue using the Product, replace or modify the Product so as to make it noninfringing, or offer to accept return of the Product and return the purchase price less a reasonable allowance for depreciation. Notwithstanding the foregoing, Seller shall have no liability for claims of infringement based on information provided by Buyer, or directed to Products delivered hereunder for which the designs are specified in whole or part by Buyer, or infringements resulting from the modification, combination or use in a system of any Product sold hereunder. The foregoing provisions of this Section shall constitute Seller's sole and exclusive liability and Buyer's sole and exclusive remedy for infringement of Intellectual Property Rights.

20. Taxes. Unless otherwise indicated, all prices and charges are exclusive of excise, sales, use, property, occupational or like taxes which may be imposed by any taxing authority upon the manufacture, sale or delivery of Products.

21. Equal Opportunity Clause. For the performance of government contracts and where dollar value of the Products exceed \$10,000, the equal employment opportunity clauses in Executive Order 11246, VEVRRA, and 41 C.F.R. §§ 60-1.4(a), 60-741.5(a), and 60-250.4, are hereby incorporated.

North America

Industrial

USA

Chicago Region

Naperville, IL
Tel: (630) 964 0796

Great Lakes Region

Fairlawn, OH
Tel: (330) 670 2680

Northeast Region

Lebanon, NJ
Tel: (908) 236 4121

Pacific Region

Buena Park, CA
Tel: (714) 228 2509

Southern Region

Alpharetta, GA
Tel: (770) 619 9767

Canada

Milton, Ontario
Tel: (905) 693 3000

México

Toluca, Edo. de
México
Tel: (52) 72 2275 4200

Mobile

USA

Global Mobile

Lincolnshire, IL
Tel: (847) 821 1500

Central Region

Lincolnshire, IL
Tel: (847) 821 1500

Eastern Region

North Canton, OH
Tel: (330) 284 3355

Midwest Region

Hiawatha, IA
Tel: (319) 393 1221

Southern Region

Aledo, TX
Tel: (817) 441 1794

Western Region

Buena Park, CA
Tel: (714) 228 2509

Canada

Milton, Ontario
Tel: (905) 693 3000

México

Apodaca, N.L.
Tel: (52) 81 8156 6000

Truck

USA

Eastern Region

Cleveland, OH
Tel: (440) 519 1125

Western Region

San Ramon, CA
Tel: (925) 735 9573

Canada

Milton, Ontario
Tel: (905) 693 3000

México

Apodaca, N.L.
Tel: (52) 81 8156 6000

Europe

Austria

Wiener Neustadt
Tel: (43) 2622 23501 0

Belgium

Nivelles
Tel: (32) 67 280 900

Czech Republic and Slovakia

Klecany
Tel: (420) 284 083 111

Denmark

Ballerup
Tel: (45) 4356 0400

Finland

Vantaa
Tel: (358) 20 753 2500

France

Contamine-sur-Arve
Tel: (33) 4 50 25 80 25

Germany

Kaarst
Tel: (49) 2131 4016 0

Greece

Athens
Tel: (30) 210 933 6450

Hungary

Budapest
Tel: (36) 1 220 4155

Ireland

County Dublin,
Baldonnell
Tel: (353) 1 466 6370

Italy

Corsico, Milano

Tel: (39) 02 45 19 21

The Netherlands

Oldenzaal
Tel: (31) 541 585000

Norway

Ski
Tel: (47) 64 91 10 00

Poland

Warsaw
Tel: (48) 22 57 32400

Portugal

Leca da Palmeira
Tel: (351) 22 999 7360

Romania

Bucharest
Tel: (40) 21 252 1382

Russia

Moscow
Tel: (7) 495 580 9145

Slovenia

Novo Mesto
Tel: (386) 7 337 6650

Spain

Madrid
Tel: (34) 91 675 7300

Sweden

Spanga
Tel: (46) 8 597 95000

Ukraine

Kiev
Tel: (380) 44 494 2731

United Kingdom

Warwick,
Tel: (44) 1926 317878

Asia Pacific

Australia

Castle Hill
Tel: (61) 2 9634 7777

China

Beijing
Tel: (86) 10 6561 0520

Shanghai

Tel: (86) 21 5031 2525

Hong Kong

Tel: (852) 2428 8008

India

Mahape, Navi Mumbai

Tel: (91) 22 5613 7081

Korea

Seoul
Tel: (82) 2 559 0400

Malaysia

Subang Jaya
Tel: (60) 3 5638 1476

New Zealand

Mt. Wellington
Tel: (64) 9 574 1744

Japan

Tokyo
Tel: (81) 3 6408 3900

Singapore

Jurong Town
Tel: (65) 6 887 6300

Taiwan

Taipei
Tel: (886) 2 2298 8987

Thailand

Bangkok
Tel: (662) 717 8140

Middle East

United Arab Emirates

Abu Dhabi
Tel: (971) 2 678 8587

Latin America

Pan American Division

Miami, FL
Tel: (305) 470 8800

Argentina

Buenos Aires
Tel: (54) 33 2744 4129

Brazil

Cachoeirinha RS
Tel: (55) 51 3470 9144

Venezuela

Caracas
Tel: (58) 212 238 5422

Africa

South Africa

Kempton Park
Tel: (27) 11 961 0700

